

MECHANICAL SPECIFICATIONS

DIMENSIONS

FIXTURE		BOXED FOR SHIPPING	
in:	10.0 x 16.7 x 21.2	in:	17 x 22 x 24
mm:	255 x 424.2 x 538.5	mm:	432 x 559 x 610

Weight: 16 kg (35 lb) **Weight:** 26.3 kg (58 lb)

Mounting Information

EC-2 can be mounted to a wall, ceiling, pole or on the ground by bolting the yoke to the foundation. It is not recommended that the EC-2 be mounted upside down without a proper yoke kit.

Colors Available: Grey, Bronze, Green, White

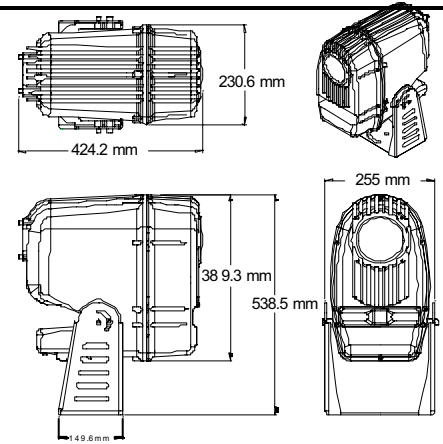

ELECTRICAL SPECIFICATIONS / LIGHT SOURCE

Lamp	CDM 150
Power Consumption	100V 50HZ @ 2.75A 120V 50HZ @ 2.3 A 230V 50HZ @ 1.1A 100V 60HZ @ 2.75A 120V 60HZ @ 2.3A 208V 60HZ @ 1.2A 277V 60HZ @ 0.9A
Rated Power	275W
Power Factor	120V, 60HZ: 0.96 230V, 50HZ: 0.90
Lamp Life	6,000 hours
Color Temperature	4,200K

	Center Beam Candela	Beam Angle Degrees	Field Angle Degrees
	37,250	15	33.4
Throw	Center Beam	Beam Diameter	Field Diameter
5	1490	1.3	3.0
10	373	2.6	6.0
15	166	3.9	9.0
20	93	5.3	12.0
25	60	6.6	15.0
30	41	7.9	18.0
35	30	9.2	21.0
40	23	10.5	24.0
45	18	11.8	27.0
50	15	13.2	30.0

For Metric figures, read "Center Beam" values as in lux, and the throw and diameters will be in meters.
For US figures, read "Center Beam" values as in footcandles, and the throw and diameters will be in feet.

$$\text{Illuminance} = \frac{\text{Candela}}{\text{Distance}^2}$$

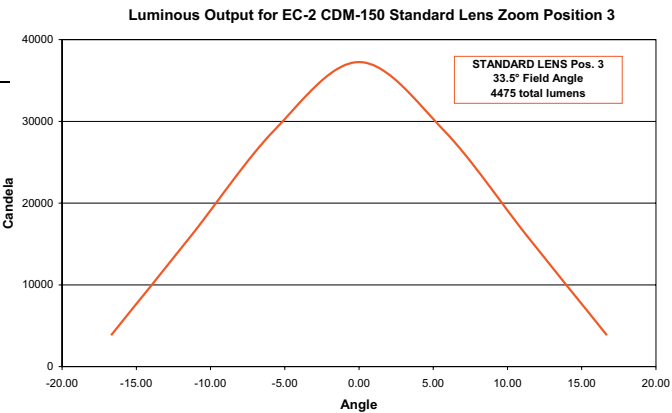

OPERATION

Pan: 0° **Tilt:** 150°

Control Options: DMX-512, Remote Preset Programming/Playback, Fixture Talkback

Field Angle: 18° - 25°(optional), 22° - 29°, or 28° - 35° (optional)

Address Methods: Wholehog II console, HandShake controller, Fixture Talkback

Software Upgrades Operating software may be downloaded from the High End Systems web site (www.highend.com), and uploaded using a High End Systems HandShake controller.

Compliances EC-2 is CE, CETL and ETL compliant.

Connector System Easy contractor access field wiring

Environmental Tolerances	Ingress Protection:	IP 66	
	E.P.A. (Effective Projected Area):	1.75 sq. ft.	Minimum Distance to Lighted Object: 1.0 m (3.28 ft.)
	Maximum Ambient Temperature, Ta:	40°C (104°F)	Minimum Distance to Flammable Object: 1.0 m (3.28 ft.)
	Maximum Winding Temperature, Tw:	180°C (356°F)	Maximum Capacitor Temperature: 85°C (185°F)

PART NUMBERS

Fixtures

49010011 - EC-2 Architectural Standard Gray
49010012 - EC-2 Architectural Bronze
49010013 - EC-2 Architectural Green

Accessories

10020001 - Handshake handheld lighting controller
49040001 - EC-2 Wall Plate 5 pin XLR
49040002 - EC-2 Standard Angle lens assembly
49040003 - EC-2 Wide Angle lens assembly
49040004 - EC-2 Narrow Angle lens assembly
49040005 - EC-2 Glare Guard
49040006 - EC-2 Wire Lens Guard
49040007 - EC-2 Beam Shaping Kit
90409080 - EC-2 kit, cable 5 pin data and power cord
55030059 - EC-2 Replacement Lamp, Phillips CDM-150

DMX CHANNELS

Channel	Function
1	Dim
2	Shutter
3	Color Function
4	Cyan
5	Magenta
6	Yellow
7	Motor Speed
8	Control

DMX Channels: 8 **Fixtures per Universe:** 64
Internal Preset Scene Memory: 1 bank, 16 scenes

COLOR WHEEL



EC-2 features CMY subtractive color mixing.