

KTA011

REV.	DESCRIPTION	DATE	ENG	ECO #	APPR
1	CREATE DRAWING	10APR06	M BELL		
2	CORRECT FAN CALLOUT: KT705, NOW KT706	16APR06	LR		

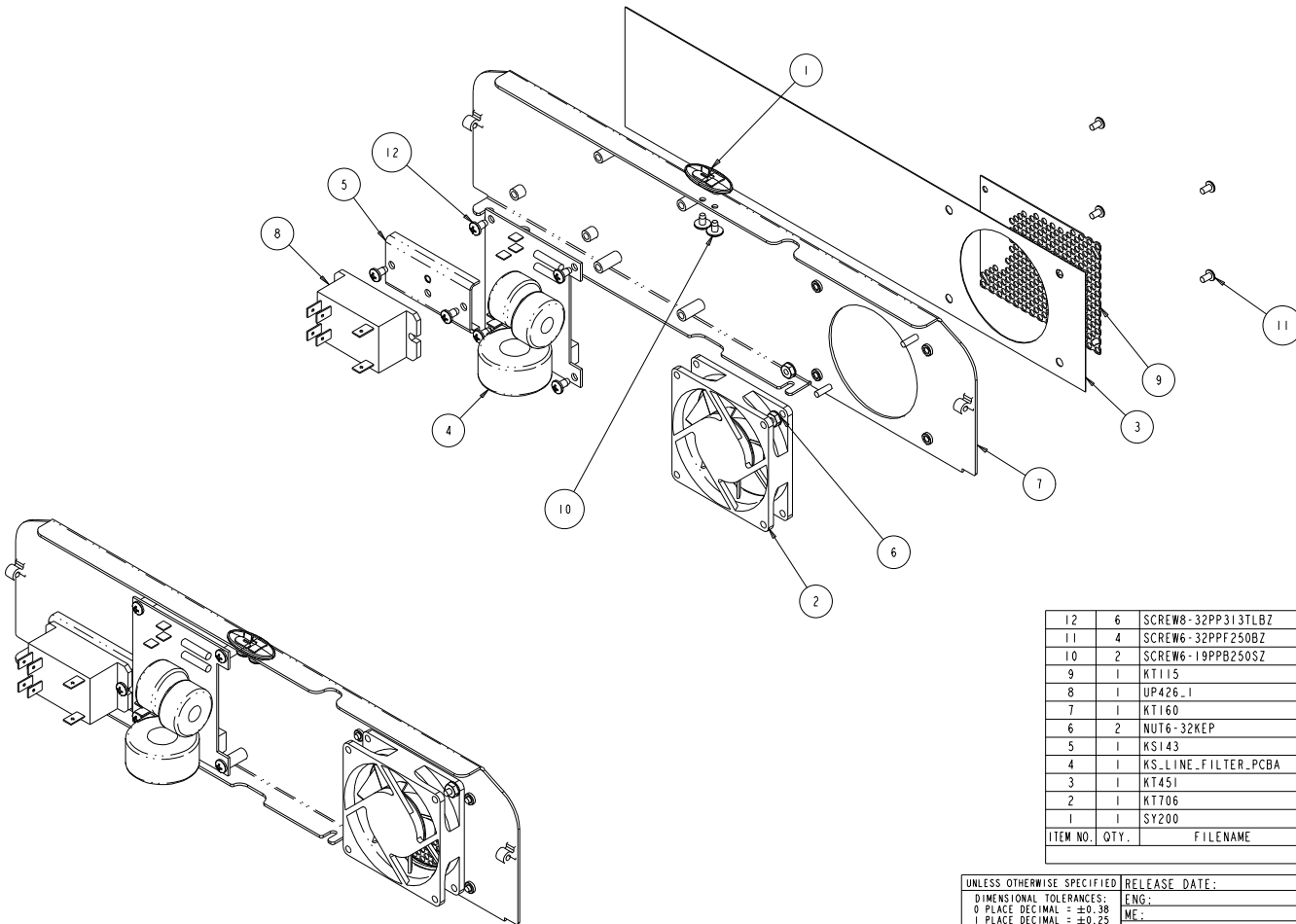

ANCILLARY DRAWING

12	6	SCREW8-32PP313TLBZ	90709065	.	SCREW, PHIL PAN 8-32 X 5/16 TAPTITE II SBZ
11	4	SCREW6-32PPF250BZ	90709012	I	SCREW, PHIL PAN 6-32 X .25 TYPE F BZ
10	2	SCREW6-19PPB250SZ	90709123	.	SCREW, 6-19 PHIL PAN 1/4 SZ PLASTITE
9	1	KT115	80071896	-	SCREEN, FAN, REAR PANEL, S-CMD-H
8	1	UP426.1	90603011	A	RELAY, 30A POWER DSPT 24V
7	1	KT160	99050055	-	PANEL, REAR, FAN, S-CMD
6	2	NUT6-32KEP	90703005	-	NUT, 6-32 KEPS NUT
5	1	KSI43	99260479	-	MOUNT, TERMINAL BLOCK S-CMD
4	1	KS.LINE.FILTER.PCBA	80010126	I	LINE FILTER PCB ASSY
3	1	KT451	99310425	A	LABEL, REAR PANEL, S-CMD-H
2	1	KT706	80270032	-	FAN, ASSY 24V DC 80MM X 20MM
1	1	SY200	90724008	-	BUTTON, LR
ITEM NO.	QTY.	FILENAME	PART NO.	REV	DESCRIPTION
BILL OF MATERIALS					

UNLESS OTHERWISE SPECIFIED:	RELEASE DATE:	CE:	 2105 GRACY FARMS LANE AUSTIN, TEXAS 78758 (512) 836-2242 FAX (512) 832-4128 ***** http://www.highend.com	
DIMENSIONAL TOLERANCES:	ENG.:	OA:		
0 PLACE DECIMAL = ±0.38	MEG.:	DRW: M BELL		
1 PLACE DECIMAL = ±0.25	MEG.:			
2 PLACE DECIMALS = ±0.13				
ANGLES = ±0.5°				
FOR PAINTED PARTS REFER TO ENG. SPEC. MANUAL WI-0582	MATERIAL:	FINISH:		
ALL COMPONENTS, MATERIALS AND FINISHES TO BE RHS COMPLIANT	CHARTED	NA		
MIN. DRAFT	INTERPRET DIMENSIONS PER ASME Y14.5M-1994	PART NO.	DRAWING NO.	
MIN. RADIUS	THIRD ANGLE PROJECTION	NA	KTA011	
FLATNESS	DIMENSIONS ARE IN MILLIMETERS	SI METRIC A1	REV.	2
THICKNESS			DO NOT SCALE	SCALE: 0.750
VOLUME				SHEET: 1 OF 1

PROPRIETARY NOTICE:
 THIS DOCUMENT CONTAINS CONFIDENTIAL AND PROPRIETARY INFORMATION OF HIGH END SYSTEMS INC., (ALSO DBA LIGHTWAVE RESEARCH) AND IS GIVEN TO THE RECEIVER IN CONFIDENCE. THE RECEIVER ACCEPTS AND AGREES THAT, EXCEPT AS AUTHORIZED BY HIGH END SYSTEMS, THE RECEIVER WILL NOT PERMIT THE USE OF THE DOCUMENT OR ANY COPY THEREOF OR THE INFORMATION THEREIN, WILL NOT COPY OR PERMIT COPYING THE DOCUMENT OR THE INFORMATION THEREIN, AND WILL UPON COMPLETION OF THE NEED TO RETAIN THE DOCUMENT, OR UPON DEMAND, RETURN THE DOCUMENT WITHOUT RETAINING ANY OF THE INFORMATION CONTAINED THEREIN IN ANY FORM WHATSOEVER.