

UPA005

REV.	DESCRIPTION	DATE	ENG	ECO #	APPR

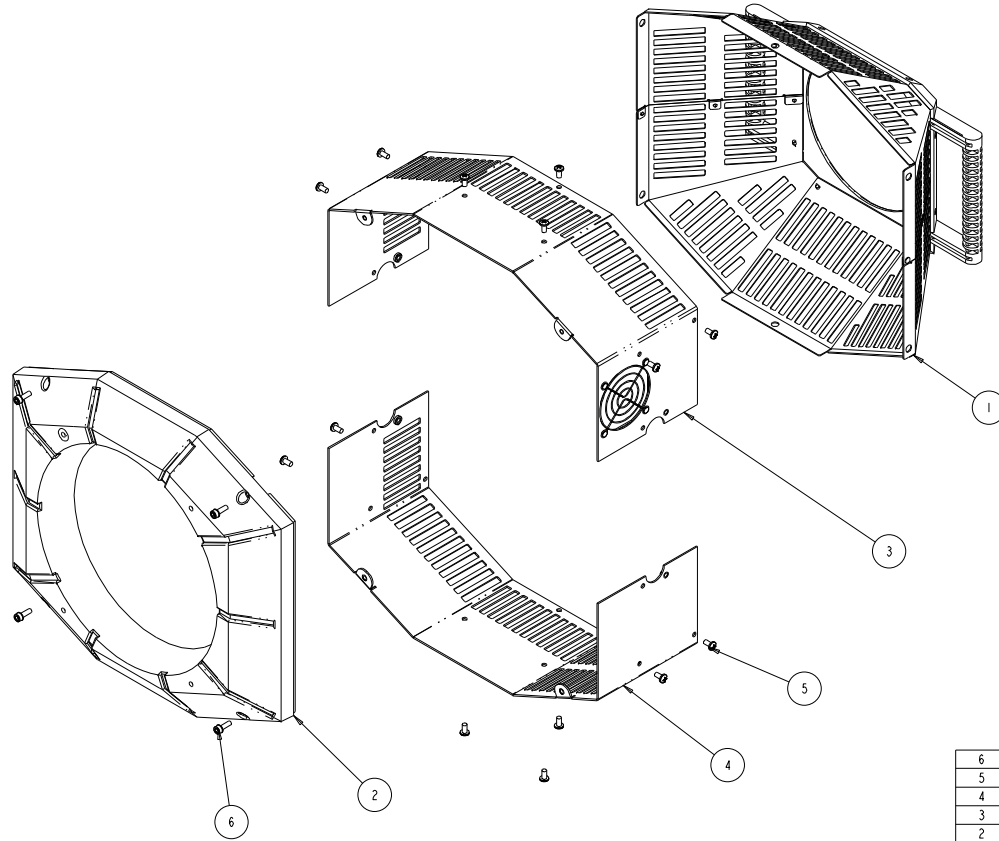

ITEM NO.	QTY.	FILENAME	PART NO.	DESCRIPTION
6	4	UP_SCRM4AC16	UP900M4.16AC	SCREW, M4 SOCKET CAP 16 BZ SEMS
5	14	UP_SCRM4PP08	.	SCREW, M4 PHIL PAN 08 BZ
4	1	UP125	UP90048T	FRAME, CENTER, OPTICAL TOP CCMD
3	1	UPA022	UP90303	COVER, ASSY CENTER CCMD
2	1	UP202	UP90008	BEZEL, FRONT CCMD
1	1	UPA010	UP90301	ASSY, REAR COVER / HANDLE CCMD

ITEM NO. QTY. FILENAME PART NO. DESCRIPTION

BILL OF MATERIALS

UNLESS OTHERWISE SPECIFIED	RELEASE DATE:	CE:	2209 WEST BRAKER LANE AUSTIN, TEXAS 78758 (512) 832-0363 FAX (512) 832-8542 ***** http://www.highend.com	
DIMENSIONAL TOLERANCES:	ENG:	OA:		
0 PLACE DECIMAL = ±0.38	ME:	DRW: L ROESSLER		
1 PLACE DECIMAL = ±0.25	MEG:			
2 PLACE DECIMALS = ±0.13	ANGLES = ±0.5°			
FOR PAINTED PARTS REFER TO ENG. SPEC. MANUAL WI-0592	MATERIAL:	FINISH:		
MIN. DRAFT	CHARTED	NONE		
MIN. RADII	INTERPRET DIMENSIONS PER ASME Y14.5M-1994	SI METRIC A1	PART NO.	DRAWING NO.
FLATNESS	THIRD ANGLE PROJECTION		UPA005	UPA005
THICKNESS	DIMENSIONS ARE IN MILLIMETERS		DO NOT SCALE	SCALE: 0.500
VOLUME				SHEET: 1 OF 1

PROPRIETARY NOTICE:
 THIS DOCUMENT CONTAINS CONFIDENTIAL AND PROPRIETARY INFORMATION OF HIGH END SYSTEMS INC., (ALSO DBA LIGHTWAVE RESEARCH) AND IS GIVEN TO THE RECEIVER IN CONFIDENCE. THE RECEIVER ACCEPTS AND AGREES THAT, EXCEPT AS AUTHORIZED BY HIGH END SYSTEMS, THE RECEIVER WILL NOT PERMIT THE USE OF THE DOCUMENT OR ANY COPY THEREOF OR THE INFORMATION THEREIN, WILL NOT COPY OR PERMIT COPYING THE DOCUMENT WILL NOT DISCLOSE TO OTHERS EITHER THE DOCUMENT OR THE INFORMATION THEREIN, AND WILL UPON COMPLETION OF THE NEED TO RETAIN THE DOCUMENT, OR UPON DEMAND, RETURN THE DOCUMENT WITHOUT RETAINING ANY OF THE INFORMATION CONTAINED THEREIN IN ANY FORM WHATSOEVER.