

MECHANICAL SPECIFICATIONS

Dimensions:
mm: 594 x 690 x 950
in: 23.4 x 24.8 x 38.4

Weight:
63.5 kg (140 lbs)

Mounting Information: The DL.3F fixture can be truss mounted using 1/4 turn camlock c-clamp mounting brackets provided. It can also stand upright on a stable surface.

Colors Available: Black

ELECTRICAL/LAMP SPECIFICATIONS

Input ratings: 100–120V 7.0A maximum 50/60Hz,
200–240V 3.5A 50/60Hz

Power factor: 0.94

Fuse: Power supply output fuse: 5A, 250V slow blow only.

Lamp: 330W NSH

Light Output: 6500 ANSI lumens

Rated Lamp Life: 2000 hours

COMPUTER

Processor: Intel Core i7-870 2.93Ghz with Hyperthreading

Memory: 2GB DD3 RAM

Hard drive: 1TB Seagate Sata

Video Card: ATI HD5770

Operating System: Windows XP embedded

PROJECTOR

Model: Sanyo PLC-XP100

Aspect ratio: 4:3 native

Brightness uniformity: 90%

Contrast ratio: 2000:1 full on/full off

Vertical Lens Shift: 107%

OPERATION

Pan: 400° **Tilt:** 240°

Movement Accuracy: Pan and Tilt from the same direction to the programmed point within approximately .01°.

Control Options: DMX512, Art-Net

Minimum Focus Distance: 1.4 meters (4.6 ft)

Compliances: CE, CSA, ETL

Video Connectors: RGBHV—BNC x 5, VGA—DB15

PART NUMBERS

Fixture

68010001: DL3 fixture, Black

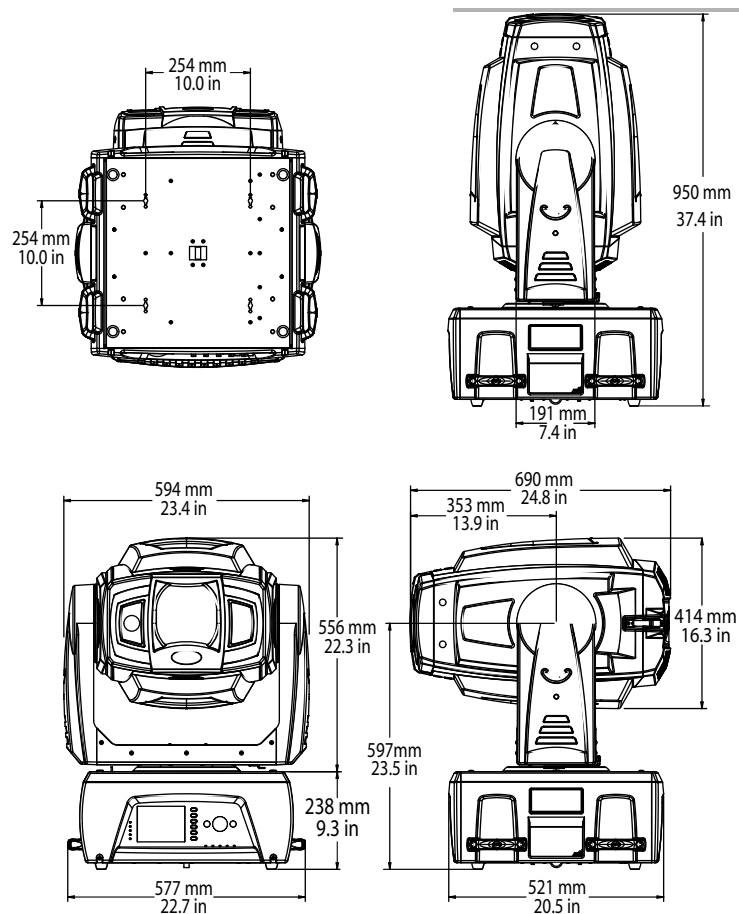

Display technology: 1.3" TFT Poly-S: x3/Color Control x1

Panel resolution: 1024 x 768

Standard Zoom Lens Throw Ratio: 1.8 - 2.4:1

Accessory Long Zoom Lens Throw Ratio: 2.4-4.3:1

Accessory Ultra Long Zoom Lens Throw Ratio: 4.3-6.0:1

Accessory Wide Angle Zoom Lens Throw Ratio:

Peripheral/Network Connectors: 2 USB ports, Gigabit Ethernet

DMX Connectors: 5-pin male and female XLR connectors

Scanning Frequency: H-sync. = 15 – 100 KHz, V-sync. = 50 – 100 Hz

Horizontal Resolution: 800 TV lines (HDTV)

Environmental Tolerances:

Ambient Operating Temperature Range: 5°–40°C (40°–104° F)

Humidity: 20%–80% (non-condensing)

Accessories

55030085EF: Replacement Lamp

67060002: Long Zoom Lens kit

67060001: Ultra Long Zoom Lens kit

68060003: Wide Angle Zoom Lens kit

DMX CHANNELS (Version 2.0)

Motion Parameters	DMX Chan	Global Parameters	DMX Chan	Graphic Object Parameters	DMX Chan									
					Obj1	Obj2	Obj3	Obj4	Obj5	Obj6	Obj7	Obj8	Obj9	
Pan	1	Global Intensity	22	Opacity	77	122	167	212	257	302	347	392	437	
	2	Global Effect 1	23	3-D Object File	78	123	168	213	258	303	348	393	438	
Tilt	3	Global Effect 1 Modifier 1	24	Media Folder	79	124	169	214	259	304	349	394	439	
	4	Global Effect 1 Modifier 2	25	Media file	80	125	170	215	260	305	350	395	440	
Dimmer	5	Global Effect 1 Modifier 3	26	In frame	81	126	171	216	261	306	351	396	441	
Focus	6	Global Effect 2	27		82	127	172	217	262	307	352	397	442	
Zoom	7	Global Effect 2 Modifier 1	28	Out frame	83	128	173	218	263	308	353	398	443	
Mspeed	8	Global Effect 2 Modifier 2	29		84	129	174	219	264	309	354	399	444	
Macro	9	Global Effect 2 Modifier 3	30	Play mode	85	130	175	220	265	310	355	400	445	
Control	10	Global Effect 3	31	Play speed	86	131	176	221	266	311	356	401	446	
Reserved	11	Global Effect 3 Modifier 1	32	Sync Mode	87	132	177	222	267	312	357	402	447	
	12	Global Effect 3 Modifier 2	33	Sync To	88	133	178	223	268	313	358	403	448	
	13	Global Effect 3 Modifier 3	34	Visual mode	89	134	179	224	269	314	359	404	449	
	14	Global Effect 4	35	Visual Mode Modifier 1	90	135	180	225	270	315	360	405	450	
	15	Global Effect 4 Modifier 1	36	Visual Mode Modifier 2	91	136	181	226	271	316	361	406	451	
	16	Global Effect 4 Modifier 2	37	Graphic Effect 1	92	137	182	227	272	317	362	407	452	
	17	Global Effect 4 Modifier 3	38	Effect 1 Modifier 1	93	138	183	228	273	318	363	408	453	
	18	Global Effect 5	39	Effect 1 Modifier 2	94	139	184	229	274	319	364	409	454	
	19	Global Effect 5 Modifier 1	40	Effect 1 Modifier 3	95	140	185	230	275	320	365	410	455	
	20	Global Effect 5 Modifier 2	41	Graphic Effect 2	96	141	186	231	276	321	366	411	456	
			Global Effect 5 Modifier 3	42	Effect 2 Modifier 1	97	142	187	232	277	322	367	412	457
			Mask Select (default iris)	43	Effect 2 Modifier 2	98	143	188	233	278	323	368	413	458
			Mask Size	44	Effect 2 Modifier 3	99	144	189	234	279	324	369	414	459
			Mask Edge	45	Graphic Effect 3	100	145	190	235	280	325	370	415	460
			Edge Fade Top	46	Effect 3 Modifier 1	101	146	191	236	281	326	371	416	461
			Edge Fade Right	47	Effect 3 Modifier 2	102	147	192	237	282	327	372	417	462
			Edge Fade Bottom	48	Effect 3 Modifier 3	103	148	193	238	283	328	373	418	463
			Edge Fade Left	49	X-axis rotation	104	149	194	239	284	329	374	419	464
			Keystone Top Left X	50		105	150	195	240	285	330	375	420	465
			Keystone Top Left Y	51	Y -axis rotation	106	151	196	241	286	331	376	421	466
		Keystone Top Right X	52	107		152	197	242	287	332	377	422	467	
		Keystone Top Right Y	53	Z-axis rotation	108	153	198	243	288	333	378	423	468	
		Keystone Bottom Right X	54		109	154	199	244	289	334	379	424	469	
		Keystone Bottom Right Y	55	Scale X	110	155	200	245	290	335	380	425	470	
		Keystone Bottom Left X	56		111	156	201	246	291	336	381	426	471	
		Keystone Bottom Left Y	57	Scale Y	112	157	202	247	292	337	382	427	472	
		Keystone X Ratio	58		113	158	203	248	293	338	383	428	473	
		Keystone Y Ratio	59	Scale Z	114	159	204	249	294	339	384	429	474	
		Framing Top Left X	60		115	160	205	250	295	340	385	430	475	
		Framing Top Left Y	61	X Position	116	161	206	251	296	341	386	431	476	
		Framing Top Right X	61		117	162	207	252	297	342	387	432	477	
		Framing Top Right Y	63	Y Position	118	163	208	253	298	343	388	433	478	
		Framing Bottom Right X	64		119	164	209	254	299	344	389	434	479	
		Framing Bottom Right Y	65	Z Position	120	165	210	255	300	345	390	435	480	
		Framing Bottom Left X	66		121	166	211	256	301	346	391	436	481	
		Framing Bottom Left Y	67											
		Viewpoint mode	68											
		Viewpoint Position X	69											
			70											
		Viewpoint Position Y	71											
			72											
		Viewpoint Position Z	73											
			74											
		Global Control	75											
		Global Control Modifier	76											

