

# ***Roadster Orbital Head System***

## **User Manual**

© High End Systems, Inc. 2006, All Rights Reserved

Information and specifications in this document are subject to change without notice. High End Systems, Inc. assumes no responsibility or liability for any errors or inaccuracies that may appear in this manual.

Trademarks used in this text: High End Systems, WholeHog III, Dataflash, Intellebeam, and LithoPatterns are registered trademarks; and Catalyst, the Catalyst Logo, the High End Systems globe logo and the Hog logo are trademarks of High End Systems, Inc. or High End Systems Europe Ltd. Belden is a registered trademark of Belden, Inc. DLP is trademark of Texas Instruments.

Other trademarks and trade names may be used in this document to refer to either the entities claiming the marks and names or their products. High End Systems disclaims any proprietary interest in trademarks and trade names owned by others.

Roadster Orbital Head System User Manual  
P/N 60600261 Version 2.1  
June, 2008

---

## Contacting High End Systems®

---

### US and the Americas

**Sales Department:** High End Systems, Inc.  
2105 Gracy Farms Lane  
Austin, TX 78758 USA  
voice: 512.836.2242  
fax: 512.837.5290

**Customer Service:** High End Systems, Inc.  
2105 Gracy Farms Lane  
Austin, TX 78758 USA  
voice: 800.890.8989  
24-hour fax: 512.834.9195  
24-hour voice mail: 512.837.3063 or 800.890.8989

**World Wide Web:** <http://www.highend.com>

---

# Declaration of Conformity

## according to ISO/IEC Guide 22 and EN45104

Manufacturer's name: High End Systems  
Distributor's name: High End Systems  
Distributor's address: 2105 Gracy Farms Lane  
Austin, TX 78758 USA

Declares that the product:  
Product Name: Roadster Orbital Head System  
Product Number: All  
Product Options: All

Conforms to the following EEC directives:  
73/23/EEC, as amended by 93/68/EEC  
89/336/EEC, as amended by 92/31/EEC and 93/68/EEC

Equipment referred to in this declaration of conformity was first manufactured in compliance with the following standards in 2002:

### Orbital Head and Power Supply

EMC: EN55022:1998 Class A  
EN61000-3-2 Class A  
EN61000-3-3 Class A  
EN50024:1998  
EN61000-4-2 Level 3 Class 2  
EN61000-4-3 Level 2  
EN61000-4-4 Level 2  
EN61000-4-5 Level 3  
EN61000-4-6 Level 2  
EN61000-4-11

### Power Supply

Safety: EN60950:2000

I, the undersigned, hereby declare that the equipment specified above conforms to the above Directives and Standards.

Ken Hansen



22 May 2003

---

## Product Modification Warning

---

High End Systems products are designed and manufactured to meet the requirements of United States and International safety regulations. Modifications to the product could affect safety and render the product non-compliant to relevant safety standards.

**Mise En Garde Contre La Modification Du Produit:** Les produits High End Systems sont conçus et fabriqués conformément aux exigences des règlements internationaux de sécurité. Toute modification du produit peut entraîner sa non conformité aux normes de sécurité en vigueur.

**Produktmodifikationswarnung:** Design und Herstellung von High End Systems entsprechen den Anforderungen der U.S. Amerikanischen und internationalen Sicherheitsvorschriften. Abänderungen dieses Produktes können dessen Sicherheit beeinträchtigen und unter Umständen gegen die diesbezüglichen Sicherheitsnormen verstoßen.

**Avvertenza Sulla Modifica Del Prodotto:** I prodotti di High End Systems sono stati progettati e fabbricati per soddisfare i requisiti delle normative di sicurezza statunitensi ed internazionali. Qualsiasi modifica al prodotto potrebbe pregiudicare la sicurezza e rendere il prodotto non conforme agli standard di sicurezza pertinenti.

**Advertencia De Modificación Del Producto:** Los productos de High End Systems están diseñados y fabricados para cumplir los requisitos de las reglamentaciones de seguridad de los Estados Unidos e internacionales. Las modificaciones al producto podrían afectar la seguridad y dejar al producto fuera de conformidad con las normas de seguridad relevantes.

## FCC Information

---

This equipment has been tested and found to comply with the limits for a Class A digital device, pursuant to part 15 of the FCC rules. These limits are designed to provide reasonable protection against harmful interference when the equipment is operated in a commercial environment. This equipment generates, uses, and can radiate radio frequency energy and, if not installed and used in accordance with the instruction manual, may cause harmful interference to radio communications. Operation of this equipment in a residential area is likely to cause harmful interference, in which case the user will be required to correct the interference at his own expense.

---

## Important Safety Information

---

Instructions pertaining to continued protection against fire, electric shock, and injury to persons are found in Appendix A. Please read all instructions prior to assembling, mounting, and operating this equipment.

**Important: Informations De Sécurité:** Les instructions se rapportant à la protection permanente contre les incendies, l'électrocution, excessif et aux blessures corporelles se trouvent dans l'Annexe A. Veuillez lire toutes les instructions avant d'assembler, de monter ou d'utiliser cet équipement.

**Wichtige Sicherheitshinweise:** Sicherheitsanleitungen zum Schutz gegen Feuer, elektrischen Schlag, und Verletzung von Personen finden Sie in Anhang A. Vor der Montage, dem Zusammenbau und der Intbetriebnahme dieses Geräts alle Anleitungen sorgfältig durchlesen.

**Informazioni Importanti Di Sicurezza:** Le istruzioni sulla protezione da incendi, folgorazione, e infortuni sono contenute nell'appendice A. Si prega di leggere tutte le istruzioni prima di assemblare, montare e azionare l'apparecchiatura.

**Informacion Importante De Seguridad:** En el Apéndice A se encuentran instrucciones sobre protección continua contra incendios, descarga eléctrica, y lesiones personales. Lea, por favor, todas las instrucciones antes del ensamblaje, montaje y operación de este equipo.

---

## Symbols

---

The following international caution and warning symbols appear in margins throughout this manual to highlight messages.



**Caution:** This symbol appears adjacent to Caution messages. Not heeding these messages could result in personal injury and/or damage to equipment.



**Warning:** This symbol appears adjacent to high voltage warning messages. Not heeding these messages could result in serious personal injury.

---

## Warranty Information

---

**Limited Warranty:** Unless otherwise stated, your *product* is covered by a one year parts and labor limited warranty. It is the owner's responsibility to furnish receipts or invoices for verification of purchase, date, and dealer or distributor. If purchase date cannot be provided, date of manufacture will be used to determine warranty period.

**Returning an Item Under Warranty for Repair:** It is necessary to obtain a Return Material Authorization (RMA) number from your dealer or point of purchase BEFORE any units

---

are returned for repair. The manufacturer will make the final determination as to whether or not the unit is covered by warranty.

Any Product unit or parts returned to High End Systems must be packaged in a suitable manner to ensure the protection of such Product unit or parts, and such package shall be clearly and prominently marked to indicate that the package contains returned Product units or parts and with an RMA number. Accompany all returned Product units or parts with a written explanation of the alleged problem or malfunction. Ship returned Product units or parts to: 2105 Gracy Farms Lane, Austin, TX 78758 USA.

**Note:** *Freight Damage Claims are invalid for fixtures shipped in non-factory boxes and packing materials.*

**Freight:** All shipping will be paid by the purchaser. Items under warranty shall have return shipping paid by the manufacturer only in the Continental United States. Under no circumstances will freight collect shipments be accepted. Prepaid shipping does not include rush expediting such as air freight. Air freight can be sent customer collect in the Continental United States.

REPAIR OR REPLACEMENT AS PROVIDED FOR UNDER THIS WARRANTY IS THE EXCLUSIVE REMEDY OF THE CONSUMER. HIGH END SYSTEMS, INC. MAKES NO WARRANTIES, EXPRESS OR IMPLIED, WITH RESPECT TO ANY PRODUCT, AND HIGH END SPECIFICALLY DISCLAIMS ANY WARRANTY OF MERCHANTABILITY OR FITNESS FOR A PARTICULAR PURPOSE. HIGH END SHALL NOT BE LIABLE FOR ANY INDIRECT, INCIDENTAL OR CONSEQUENTIAL DAMAGE, INCLUDING LOST PROFITS, SUSTAINED OR INCURRED IN CONNECTION WITH ANY PRODUCT OR CAUSED BY PRODUCT DEFECTS OR THE PARTIAL OR TOTAL FAILURE OF ANY PRODUCT REGARDLESS OF THE FORM OF ACTION, WHETHER IN CONTRACT, TORT (INCLUDING NEGLIGENCE), STRICT LIABILITY OR OTHERWISE, AND WHETHER OR NOT SUCH DAMAGE WAS FORESEEN OR UNFORESEEN.

Warranty is void if the product is misused, damaged, modified in any way, or for unauthorized repairs or parts. This warranty gives you specific legal rights, and you may also have other rights which vary from state to state.

---

## Table of Contents

User Manual .....	i
Contacting High End Systems® .....	ii
Product Modification Warning .....	iv
FCC Information .....	iv
Important Safety Information .....	v
Symbols .....	v
Warranty Information .....	v

### **Product Overview ..... 1**

Orbital Movement System Features .....	1
Accessories .....	2
Specifications .....	3
Physical Specifications .....	3
Mirror Head .....	3
Power Hub .....	4
Roadcase .....	4
Projector Lens Options .....	4
Electrical Specifications .....	5
Environmental Specifications .....	5
Cable and Connector Specifications .....	5
DMX and Modul Link .....	5
Power Hub to Christie Digital Projector Connection .....	5
Mirror Head to Power Hub Connection .....	6

### **Setup and Configuration ..... 7**

Inspecting the Fixture .....	7
Hardware .....	7
Cabling .....	7
Save All Shipping Materials .....	7
Installing Power Cord Caps .....	7
Installing a Line Cord Cap - U.K. Only .....	8
Vatic Fitter Heads Information - Danmark .....	8
System Setup .....	9
Mounting .....	9
Mounting the Orbital Head .....	9
Mounting the Power Hub .....	10

---

Connecting the System .....	11
Power Hub Connections .....	11
Power Hub to Projector .....	12
Power Hub to Orbital Head Connection .....	12
DMX Data Connection .....	12
Connecting to a DMX512 Link .....	12
Required Data Cabling and Connectors .....	12
Constructing a Terminator .....	13
Setting Up a DMX Link .....	13
Powering On the System .....	14
Before Applying Power .....	14
Applying Power .....	14
Verifying/Uploading Catalyst Software .....	15
Setting a DMX Start Channel .....	15

**Operation and Maintenance ..... 17**

The Power Hub Menu Display .....	17
Navigational Basics .....	18
Display in Menu Locked Mode .....	18
Fixture Software Version .....	18
System Configuration Type .....	18
DMX Start Channel .....	18
Error Message Display .....	18
Unlocking the Menu System .....	19
Exiting the Menu System .....	19
Menu Map .....	19
DMX Address Menu .....	21
Setting a DMX Start Channel .....	21
Set Parameters Menu .....	21
Factory Default Settings .....	21
Display Level .....	22
Lamp Control ... .....	22
Mirror 2 Quick Path .....	22
LensType .....	23
Fixture Mode Menu .....	23
Crossloading Fixture Software .....	23
Protocol Mode .....	24

---

Test Options Menu .....	24
Copying the Boot Code .....	24
Homing the Fixture .....	24
Self Test Menu .....	25
Information Menu .....	25
Channels Needed .....	25
Display Errors .....	25
DMX Values Menu .....	26
Fixture Hours .....	26
Fixture Hours Reset .....	26
Module Version Menu .....	27
Next DMX Channel .....	27
Sensor Status Menu .....	27
Software Version .....	27
Unique Number .....	27
Power Hub Maintenance .....	28
Replacing the Power Hub Fuse .....	28
Replacement Parts .....	28
Cleaning the Mirrors .....	28
<b>DMX Programming .....</b>	<b>29</b>
DMX Programming Terminology .....	29
DMX Parameters .....	29
Roadster Orbital Head Positioning .....	29
Focus .....	29
Zoom .....	29
Shutter .....	29
MSpeed (Motor Speed) .....	30
Control Function .....	31
DMX Protocol Table .....	32
<b>MSpeed Conversion Table .....</b>	<b>35</b>
<b>Safety Information .....</b>	<b>37</b>
Appendice B: Importantes Informations Sur La Sécurité .....	38
Anhang B: Wichtige Hinweise Für Ihre Sicherheit .....	39
Apéndice B: Información Importante De Seguridad .....	40
Appendice B: Importanti Informazioni Di Sicurezza .....	41
Vigtig Sikkerhedsinformation .....	41



# Chapter I:

## Product Overview

The Roadster Orbital Movement system from High End Systems® utilizes a moving mirror head mounted on the front of a Christie Digital Roadster S+12/16 3-chip, DLP®-based projector to position a projected image anywhere in three-dimensional space. A power hub component mounts separately to allow DMX control of the Orbital Head movement and projector shutter, lamp, focus and zoom. It operates with the Catalyst® Media Server (a separate product that provides real-time video rendering) or independently as a standalone fixture on a DMX link.

The Roadster Orbital Movement System system ships with:

- A Periscopic Dual-Mirror Orbital Head
- A bracket kit for mounting the Orbital Head to a Christie Digital Roadster Projector
- A Power Hub with truss mounting bracket
- Cabling for XLR, RS-232 and power connections

A System using a dual Mirror Head and a Catalyst Media Server version 1.2 requires a DMX lighting console that can control 56 channels per fixture and support true 16-bit values on 15+ channels. The Wholehog III™, Hog iPC, Hog 1000, and Hog 500 lighting consoles are DMX controllers available from High End Systems to control the Catalyst system (see *Accessories on page 2*). Contact the controller's vendor regarding Catalyst support on other DMX controllers. For more information on operating the fixture with a controller (or control device such as DMX control software), consult controller documentation.

A video wall, LED panel, or other video display may be required for a specific application.

The Roadster Orbital Movement System customized roadcase is available separately as part number 56010001.

## Orbital Movement System Features

---

- USITT DMX512 compatible control
- High resolution stepper motors (180,000 steps per revolution) to provide smooth, 16-bit DMX movement control
- Quick Path feature to allow faster position changes in Mirror 2 movement
- Mounting hardware to allow mounting to a Christie S+12K or S+16K projector.
- Universal variable 100–230V power input
- On-board menu system with dot matrix display
- RS-232 connection for projector control

## Accessories

---

The following table lists accessories available for the Roadster Orbital Movement System from your High End dealer/distributor. For more information, contact your High End Systems dealer/distributor or see "Contacting High End Systems" on page ii.

<b>Part Description</b>	<b>Part Number</b>
Additional Power Hub for Roadster Orbital Movement System	56040011
Catalyst Interface Box	56040004
Catalyst Outer Mirror	80180006
Catalyst Inner Mirror	80180007
Digital Media Server	56020001
LCD Monitor	56070009
Galvanized safety cable	12040001
Cheeseborough clamp	55040014
Lightwave Research Upload Dongle	26040002
Male 5-pin DMX terminator	90404039
Heavy duty 5-pin XLR cable (10')	55050017
Heavy duty 5-pin XLR cable (25')	55050018
Heavy duty 5-pin XLR cable (50')	55050019
Heavy duty 5-pin XLR cable (100')	55050020
4-pin XLR Modular Link cable	90409125

## Specifications

### Physical Specifications

#### Mirror Head

**Dimensions:** 349mm x 369mm x 686mm (13.7in x 14.5in x 27in).

**Weight:** 12.7kg (28lbs)

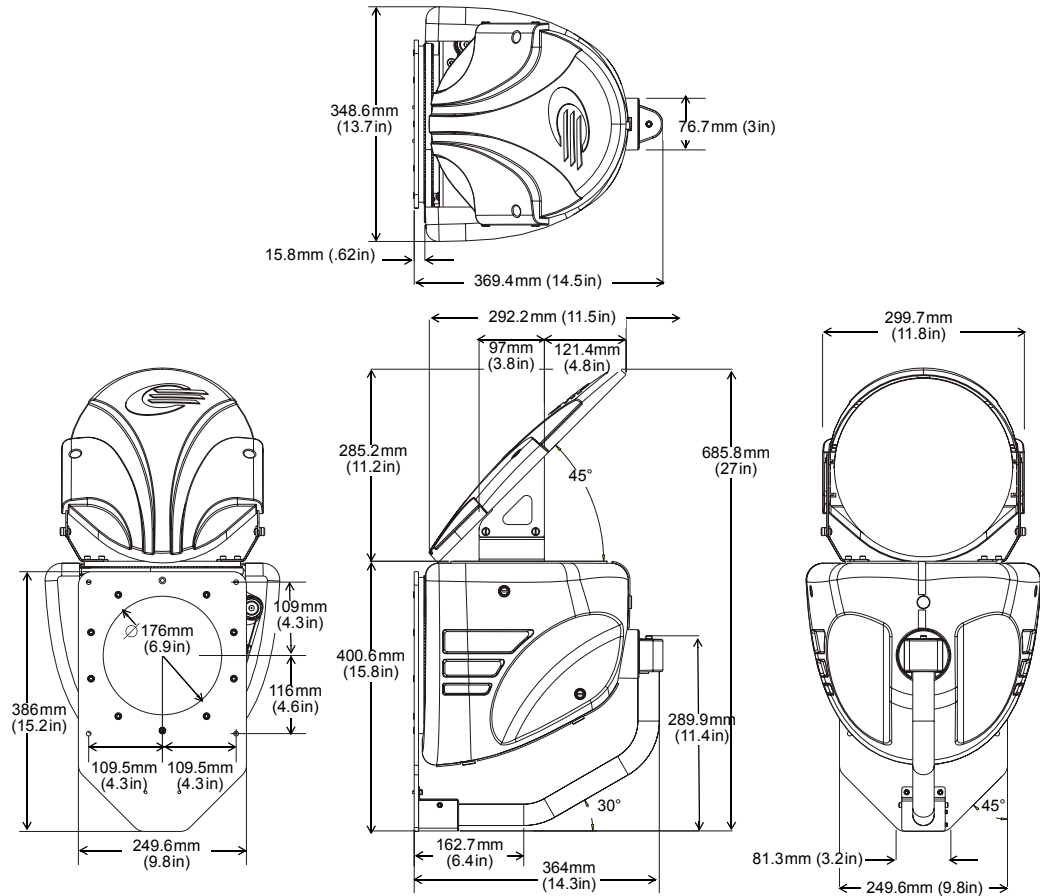

## Power Hub

**Dimensions:** 276mm x 301mm x 120mm (10.9in x 11.8in x 4.7in).

**Weight:** 2.3kg (5lbs)

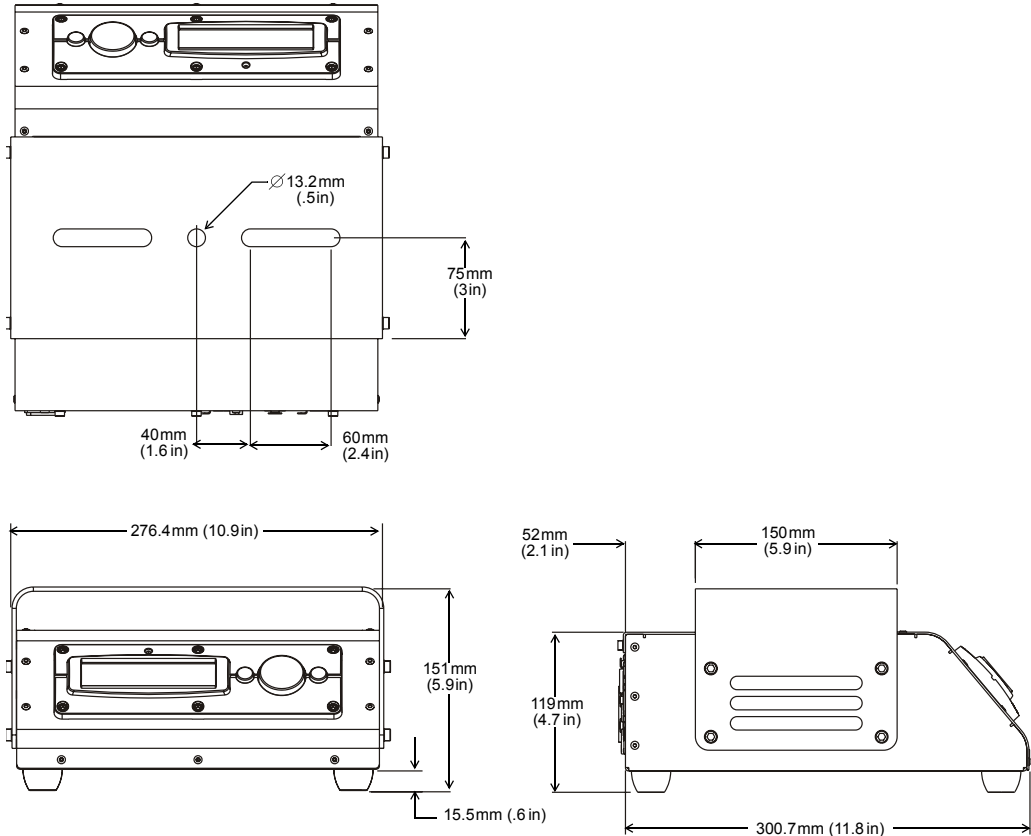

## Roadcase

**Dimensions (including casters):** 1150 mm x 622mm x 660mm (45in x 24.5in x 26in)

**Weight (with components loaded):** 71.7kg (158lbs)

## Projector Lens Options

Christie Digital Roadster S-12K or S16K with one of the following lens options:

Christie Part #	Lens	Description
38-809091-01	2.5-4.5:1 Zoom Lens	When used with the SXGA+ products, this lens has a 2.5-4.5:1 throw ratio. If used with the DW3K or DW6K, the lens will provide a 2.8-5.0:1 throw ratio.
38-809092-01	4.5-7.3:1 Zoom Lens	When used with the SXGA+ products, this lens has a 4.5-7.3:1 throw ratio. If used with the DW3K or DW6K, the lens will provide a 5.0-8.0:1 throw ratio.

## Electrical Specifications

The following electrical specifications apply to the Power Hub component of the Roadster Orbital Movement System.



**Warning: Class I equipment – This equipment must be earthed**

Universal Input from 100–230 VAC, (50–60Hz)

**Rated power:** 100 W

**Fuse:** Power supply output fuse: 2.5A, 250V slow blow only.

## Environmental Specifications

**Maximum ambient temperature (Ta):** 40° C

**IP Rating:** IP 20

## Cable and Connector Specifications

### DMX and Modual Link

**Cables:** Belden 9841 or equivalent (meets specifications for EIA RS-485 applications) with the following characteristics:

- 4-conductor two twisted pairs plus a shield
- Maximum capacitance between conductors: 30 pF/ft
- Maximum capacitance between conductor and shield: 55 pF/ft
- Maximum resistance: 20 Ohm/100 ft
- Nominal impedance: 100–140 Ohm

**Connectors:** Two 5-pin male and female XLR connectors:

- Pin 1 Ground
- Pin 2 Data–
- Pin 3 Data+
- Pin 4 Secondary data–
- Pin 5 Secondary data+

**Terminator:** 5-pin male XLR connector with a 120 Ohm terminating resistor fitted between pins 2 and 3.

### Power Hub to Christie Digital Projector Connection

**Cable:** DB9 M-F RS-232

## Mirror Head to Power Hub Connection

**Cable:** 4-conductor, 1.5 mm<sup>2</sup> with a maximum length of 2 meters.

**Connectors:** 4-pin male and female XLR connectors:

- Pin 1 Ground
- Pin 2 Data Complement
- Pin 3 Data True
- Pin 4 +40V

# Chapter 2:

## Setup and Configuration

### Inspecting the Fixture

---

The following components are shipped as the Roadster Orbital Head system:

#### Hardware

- Orbital Head fixture
- Power Hub
- Mounting Bracket for Christie projector

#### Cabling

- 4-pin XLR Power hub cable
- RS 232 cable
- US power cable
- European power cable

Unpack all components and verify that it is undamaged. Inspect both the outside of the components for physical damage and the optical surfaces of the Orbital Head. If the product is damaged or there are items missing, notify both the shipping agent and your sales agent immediately.

### Save All Shipping Materials

Do not discard shipping materials. Packing materials are specifically designed to protect the product during transport.

High End Systems® assumes no responsibility for products that are damaged during transport. Return a product for repair in its original shipping carton and packing materials.

Before sending anything to the factory, call your High End Systems dealer/distributor for a Return Material Authorization (RMA) number. The factory cannot accept any goods shipped without an RMA number.

### Installing Power Cord Caps

---

The Power Hub for the Orbital Head System may ship without an attached power cord cap. Different locations (even within the same country) may require a different power cord cap to connect the fixture to a power outlet.

Because of the variety of power cord caps used worldwide, High End Systems, Inc. cannot make specific recommendations for the power cord cap.

Contact a local authority for the type of power cord cap needed. When installing the power cord cap, note that the cores in the mains lead are colored in accordance with the following code:

- green and yellow = earth
- blue = neutral
- brown = line



**Warning: Class 1 equipment - This equipment must be earthed.**

### Installing a Line Cord Cap - U.K. Only

In the United Kingdom, the colours of the cores in the mains lead of this equipment may not correspond with the coloured markings identifying the terminals in the fixture's plug.

Therefore, install a line cord cap in accordance with the following code:

- The core which is coloured green and yellow must be connected to the plug terminal which is marked with the letter "E," or by the earth symbol , or coloured green, or green and yellow.
- The core which is coloured blue must be connected to the terminal which is marked with the letter "N" or coloured black.
- The core which is coloured brown must be connected to the terminal which is marked with the letter "L" or coloured red.

### Vatic Fitter Heads Information - Danmark

**Advarsel:** Beskyttelse mod elektrisk chock.

Vigtigt!

Lederne med gul/groen isolation maa kun tilsluttes en klemme maerket



## System Setup

### Mounting



**Warnings: Equipment suitable for dry locations only. Do not expose this equipment to rain or moisture.**



**Caution: If mirror surface needs to be cleaned during setup procedure, use only a mild glass cleaner (containing no ammonia) and a soft, lint-free cotton cloth to avoid scratching mirror surface.**

The Roadster Orbital Head system ships with a mounting bracket adapted to the Christie Roadster S+12 or S+16 high output video projectors. The Orbital Head must be able to rotate freely. Choose from the recommended lens options to avoid impeding Orbital Head movement, (see *Projector Lens Options* on page 4).

### Mounting the Orbital Head

To mount the Orbital Head to the projector:

1. Choose from the four available orientation options:

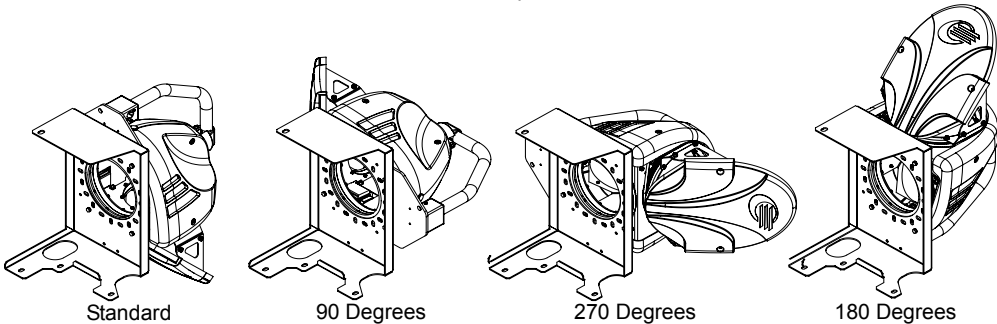

2. Mount the bracket to the Orbital head using four M6 x 16mm hex bolts with lock washers and flat washers **(A)**.

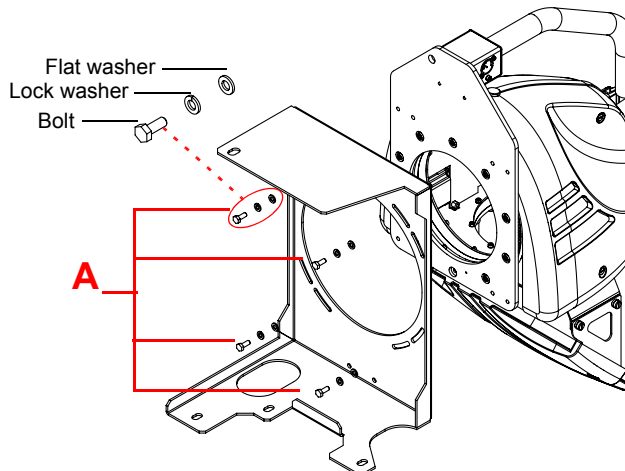

3. Remove the three existing projector M10 x 20mm hex bolts and lock washers (**B**).
4. Retract projector foot (**C**) to minimum height to accommodate the bracket.
5. Slide the bracket over the projector.
6. Insert the three provided spacers (**D**) between the bracket and the projector
7. Reinstall the three hex bolts and washers (**B**) through the spacers.
8. If you are not using the lifter eyes on the projector for truss mounting, install the optional M12 x 35mm hex bolt, lock washer and flat washer (**F**) provided to secure the bracket to the projector.

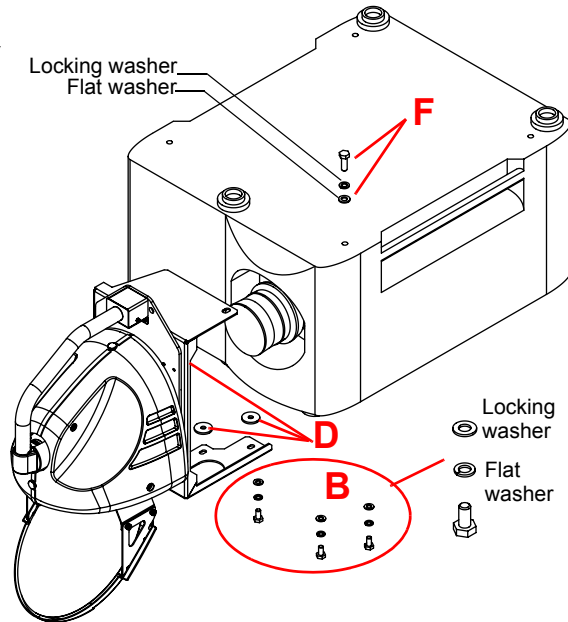
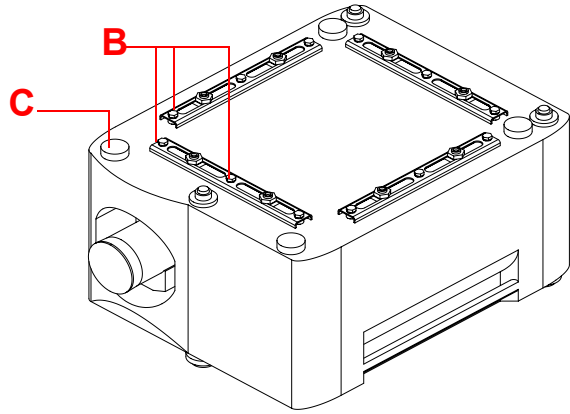

### Mounting the Power Hub

Attach one or two cheeseborough clamps to the mounting bracket for mounting on any standard truss. Use safety cable to secure the Power Hub to an independent support.

**Note:** *The Power Hub must be located within two meters of the projector head for correct performance.*

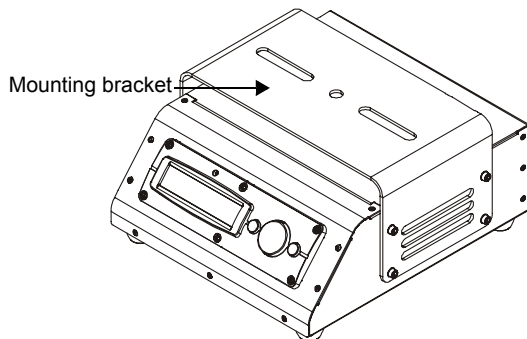



### Power Hub to Projector

The power hub RS-232 connection to the projector allows DMX control of the projector's shutter, lamp, focus and zoom function.

### Power Hub to Orbital Head Connection

The Power Hub provides data and power to the Orbital Head through the two meter, 4-pin XLR cable provided. This cable should not be lengthened.

**Note:** *The cable has 1.5 mm<sup>2</sup> cores designed to carry power to the Orbital Head. Do not substitute a microphone or similar cable.*

### DMX Data Connection

The Power Hub connects to a DMX controller or another fixture on a DMX 512 link using a 5-pin DMX512 data connector compliant with the USITT standard. See *Connecting to a DMX512 Link* for detailed instructions on data cable construction and connection.

### Connecting to a DMX512 Link

The Orbital Head System can be controlled with a DMX console on a DMX512 link for real time image manipulation and positioning.

The Orbital Head System can also operate without the server as a standalone fixture on a DMX link to position projector output utilizing the moving Orbital Head.

### Required Data Cabling and Connectors

To link one or more fixtures to a controller and/or to each other, obtain data cabling. Cabling can be purchased from High End Systems® (see *Accessories* on page 2) or constructed according to the following specifications.

High End Systems® recommends data-grade cable. Data-grade cable is designed to carry a high-quality signal with less susceptibility to electromagnetic interference.

**DMX Data Cables:** Use Belden® 9842 or equivalent (meets specifications for EIA RS-485 applications) data cables with the following characteristics:

- Two twisted pairs (4-conductors) plus a shield
- Maximum capacitance between conductors: <15 pF/ft.
- Maximum capacitance between conductor and shield: 55 pF/ft.
- Maximum resistance: 20  $\Omega$ /1000 ft.
- Nominal impedance: 120  $\Omega$

**Cable Connectors:** The Power Hub accepts 5-pin XLR cable connectors. Cabling must have a male XLR connector on one end of the cable and a female XLR connector on the other end.

Pin one is the common (cable shield), pin two is the data complement (negative), pin three is the data true (positive). Pins four and five are not used, but they allow a secondary data link to pass through the fixture, (see ).

Test each cable with a voltage/ohm meter (VOM) to verify correct polarity and to make sure that the negative and positive pins are not grounded or shorted to the shield or to each other.



**Caution: Do not connect anything to the ground lug on the XLR connectors. Do not connect or allow contact between the common (cable shield) and the fixture's chassis ground. Grounding the common could cause a ground loop and/or erratic behavior.**

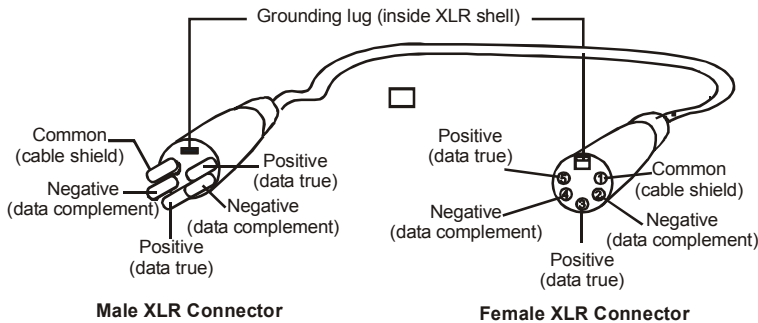

**XLR 5-pin connector cable**

### Constructing a Terminator

Install a 120 ohm, 1/4 watt (minimum) terminator in the fixture's Data Out (female) cable connector in the *last* fixture on each DMX link. A terminator on the last fixture of the link prevents data reflection, which can corrupt the data communication on the link.

Purchase a terminator from a High End Systems dealer/distributor (see *Accessories* on page 2), or follow the instructions below to construct a terminator.

To construct a terminator:

1. Disassemble a male 5-pin XLR connector.
2. Solder a 120 ohm resistor, minimum of 1/4 watt, between pins two and three (see 3.).
3. Reassemble the XLR connector

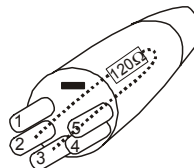

**Data cable terminator**

### Setting Up a DMX Link

Each fixture on a DMX link has a data in and a data out (through) connection. The Roadster Orbital Head functions as a fixture on the link using 12 channels to control mirror movement and projector lens functions. The controller sends commands through the Power Hub to control mirror movement and position an image from the projector. The Roadster Orbital Head can be daisy-chained to other automated lighting fixtures on the link.

To connect the Roadster Orbital Head to a DMX link:

1. Connect the male XLR connector of a DMX data cable to the controller's DMX 'data out' connector.
2. Connect the Data cable's female XLR connector to the 'data in' connector of the first (or next) unit on the DMX link. This connection is on the Power hub for the Orbital Head system.

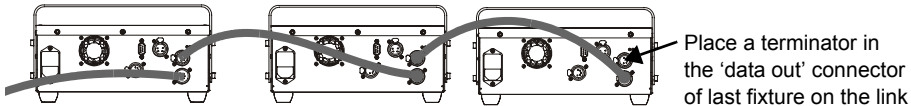

**Daisy-chaining Power Hubs in a DMX 512 link**

3. Continue linking the remaining fixtures connecting a cable from the 'data out' (data thru) connector of each fixture to the 'data in' connector of the next fixture on the link.
4. Connect a male terminator to the 'data out' connector of the last fixture in the link.

## Powering On the System

---



**Warnings: Connect this equipment only to a branch circuit having a maximum overload protection of 20 A.**

**The Mirror Head moves under remote control, and is designed for use by proficient technicians in a professional environment.**



**Caution: Do not power on the fixture until verifying that the line cord cap is suitable for the power source in your location.**

**Keep hands free from the Mirror Head when powering up the system to avoid a pinching hazard as the Mirror Head begins to move during automatic homing.**

### Before Applying Power

- Manually rotate the Mirror Head, checking that it can move freely on both axes without hitting the projector or any rigging hardware.
- Ensure that all cables, set pieces etc. are clear of the equipment.
- Keep all clothing and body parts clear of the equipment.
- Ensure that the equipment may not be accessed by the public or unqualified persons.

### Applying Power



**Caution: Keep hands free from the Mirror Head when powering up the system to avoid a pinching hazard as the Mirror Head begins to move during automatic homing.**

To apply power, connect the appropriate Power Hub line cord into your power source. For more information on attaching a linecord, see *Installing Power Cord Caps* on page 7.

Once connected to power, the Orbital Head will initialize (home). During this process, both mirrors on the Mirror Head rotate to locate end stops and verify that the fixture is operating correctly.

## Verifying/Uploading Catalyst Software

---

Check the Power Hub display in the Menu Locked mode to identify the software version loaded on that fixture. Verify that the version displayed by the fixture is the latest available. The latest software for the Roadster Orbital Head system is available in the support section of the High End Systems web site ([www.highend.com/support](http://www.highend.com/support)). There are two ways to upload new software to the Roadster Orbital Head system:

1. Attach a High End Systems Upload Dongle to your computer and upload the software to your Roadster Orbital Head system using WinUpload software.

WinUpload software requires a computer running Microsoft® Windows® 95, 98, ME, XP, or 2000 operating system. To Install the WinUpload Software, create a WinUpload folder on your hard drive. Download the Upload Module from [www.highend.com/support](http://www.highend.com/support) page for your product and copy the WinUpload.exe and inpout32.dll files into the folder on your hard drive.

2. Crossload software from one fixture that contains the new software to all other Roadster Orbital Head systems on the link, (see *Crossloading Fixture Software (XLD)* on page 32.

**Note:** *Before you can upload new software, you must disconnect any controllers, bypass any serial data distributors and/or data line optoisolators, and bypass or make sure that any fixtures using RS-422 communications (such as Dataflash® AF1000 xenon strobes, and Intellabeam® fixtures) are located after the Studio Command fixtures on the link. These devices will block communication with any other Studio Command fixtures on the link.*

## Setting a DMX Start Channel

---

A lighting console uses a start channel to identify the range of channels on a DMX link associated with a particular fixture. A standard DMX512 link has 512 available channels to divide among *all* the devices on the link. The start channel is the first channel in a designated fixture's channel range. A fixture must have a *unique* channel range to respond *independently* to controller commands.

To determine a valid start channel for a fixture, first identify the channel range (the number of consecutive channels a fixture requires) of every fixture on the link. Each Orbital Head System requires a block of 12 consecutive channels on a 512-Channel DMX link.

Set the start channel using the Power Hub's onboard menu system.

To set the DMX start channel on the Power Hub:

1. Press the Menu button to unlock the menu system or to move back up the system to the top level menus. **DMX ADDRESS MENU** is the first menu item at the top level.
1. Press the Enter button to select. The display will show **SET DMX START CHANNEL:###**. The display will show the start channel currently assigned to the fixture.
2. Use the up and down arrows on the Navigation button to select a new DMX start channel, if necessary. The display will flash a new option ready for selection.

**Note:** *The last valid Start channel for a fixture on a DMX link is based on the channel range required by fixture's module configuration. The last valid Start channel for the Orbital Head System 501 (512–12+1).*

3. Press the Enter button to accept the new DMX start channel.

**Note:** *If the Enter button is not pressed, the old value will remain selected after exiting the menu.*

For more information on navigating the menu system, see *The Power Hub Menu Display* on page 17.

# Chapter 3:

## Operation and Maintenance

This chapter discusses the onboard menu system for the Orbital Head System. For more information on operating the fixture with a controller, consult the controller documentation.

The Power Hub has an on-board menu system allows you to:

- Set a start channel
- Enable and disable default parameter settings
- View protocol type
- Crossload firmware
- Home the Mirror Head
- Test movement and sensor functions
- View current DMX values for all parameters
- View fixture number, software version, errors, channels needed, and next available DMX channel.
- Strike and douse the projector lamp



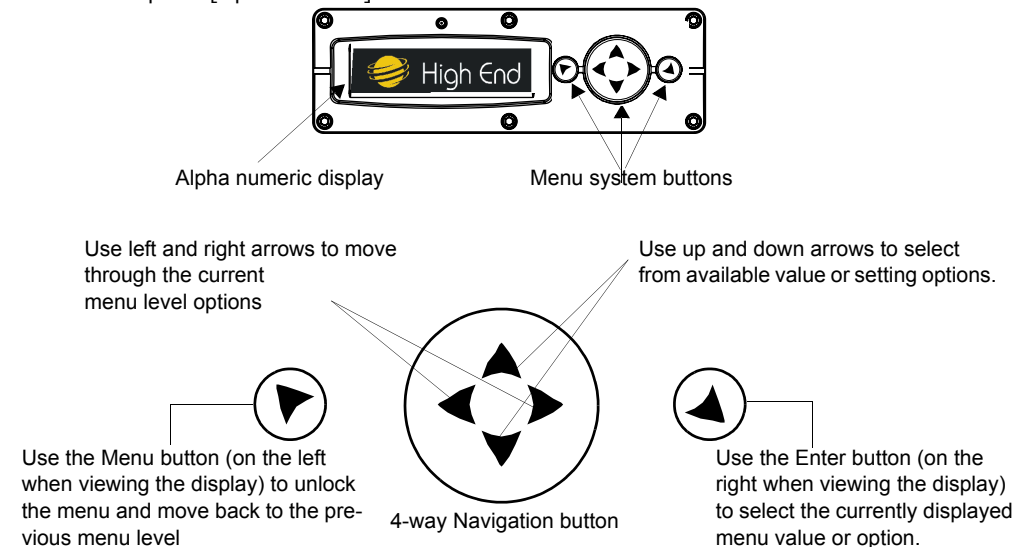

### The Power Hub Menu Display

The front panel on the Power Hub component has a dot matrix display and six arrows on buttons that control navigation for the on-board menu system. The buttons are configured with the Menu button on the left and the Enter button on the right. The center button navigates through the current level of menu options [Left and Right] and values available for the current option [Up and Down].



## Navigational Basics

---

1. Unlock the Menu system by pressing the Menu  button for a few seconds until the display goes to the 2-line format.
2. Use the left and right arrows   on the 4-way Navigation button to scroll through Menu options at the current level.
3. Stop at the desired menu and press the Enter  button to select. The new option will not be stored unless the Enter button is pressed.
4. If there is another level of menu choices repeat Steps 2 and 3.
5. At the option or setting menu level, use the up and down arrows on the Navigation button  to scroll to the desired option or setting. The option flashes until the Enter button is pressed. Pressing the Enter button stores the new value for that option. Pressing the Menu button returns to the previous menu level *without changing* the value of an option.
6. Continue pressing the Menu button to move back up levels and exit the menu system.

## Display in Menu Locked Mode

---

The Power Hub display panel gives access to the onboard Menu System. When the Menu System is in locked mode, the panel displays in large 8-character words designed to be viewed from a distance. Under normal circumstances, when the display is locked, it cycles between displaying the fixture's software version [V###.###], the High End Systems logo, the Catalyst logo, the fixture's configuration type [ROADSTER] and the fixture's DMX Start channel [DMX\_C###]. Any errors present are also displayed in an 8-character error description.

### Fixture Software Version

The software version loaded on the system can vary even between units purchased at the same time. *Verifying/Uploading Catalyst Software* on page 15 describes the procedures to ensure that all Roadster Orbital Head systems on the link are running the latest software.

### System Configuration Type

The configuration type indicates the system's modular setup.

### DMX Start Channel

The DMX start channel is the first channel currently assigned to that fixture in its range of channels on a DMX link. For more information on DMX start channels, see *Setting a DMX Start Channel* on page 15.

### Error Message Display

Errors are displayed in short 8-character form when the menu system is locked. Unlocked, menu system's 2-line format displays more detailed information.

## Unlocking the Menu System

To unlock the menu system, press and hold the Menu button until the display changes to the 2-line format. The menu system is protected against inadvertent menu changes by requiring the Menu button to be held for a few seconds before allowing entry to the menus. DMX Address Menu is the first option on the top menu level.

## Exiting the Menu System

To exit the menu system, keep pressing the Menu button to back out of each menu level until the High End Systems logo appears. The word AUTOLOCK will appear briefly on the display to indicate the fixture's software is "locking" the display. The display switches back to the large 8-character format and, after a few seconds, begins the standard display for the locked mode as described above.

## Menu Map

Use the following table to navigate the menu options on the Power Hub.

Level 1	Level 2	Level 3	Option/Setting	Description/Notes
▼ enters /exits Menu System and moves up levels ◀ ▶ moves between items on same level. ▲ selects			▲ scrolls between values ▲ selects	
<b>DMX ADDRESS MENU</b>	<b>SET DMX START CHANNEL: ###</b>		<b>1-512</b>	Selected value becomes the first DMX value in the range for that Mirror Head on a DMX 512 link.
<b>SET PARAMETERS MENU</b>	<b>FACTORY DEFAULT SETTINGS: ###</b>		<b>ON</b>	Reverts Mirror Head to default setting
			<b>OFF</b>	Indicates a factory default has changed
	<b>DISPLAY LEVEL:</b>		<b>ON</b>	Turns display on
			<b>OFF</b>	Dims Display when menu is locked
	<b>LAMP CONTROL MODE</b>		<b>AUTOMATIC</b>	Douses Lamp after a 5 minute DMX data loss
			<b>MANUAL</b>	Lamp dousing controlled manually
	<b>LENS TYPE</b>		<b>7.7-11.2:1</b>	Selects the installed Lens type
			<b>4.1-6.9:1</b>	
		<b>2.6-4.1:1</b>		
<b>MIRROR 2 QUICK PATH:</b>		<b>ON</b>	Allows mirror to take the shortest path to the selected position	
		<b>OFF</b>	Disables the Quick-Path feature	
<b>FIXTURE MODE MENU</b>	<b>PROTOCOL MODE:</b>		<b>STANDARD</b>	Factory default setting
	<b>CROSSLOAD FIRMWARE:</b>		<b>NO</b>	Safe setting
			<b>YES</b>	Uploads Catalyst software to all other Catalyst fixtures on the link

Level 1	Level 2	Level 3	Option/Setting	Description/Notes	
▼ enters /exits Menu System and moves up levels		◀▶		◆ scrolls between values	
moves between items on same level.		▲ selects		▲ selects	
<b>TEST OPTIONS MENU</b>	<b>HOME FIXTURE:</b>		<b>ALL</b>	Homes the Mirror Head	
	<b>LAMP STATE</b>		<b>ON</b>	Tests projector lamp function	
			<b>OFF</b>		
	<b>COPY BOOT:</b>		<b>NO</b>	Safe position: no action when selected	
			<b>YES</b>	Copies boot code to fixture	
	<b>SELF TEST MENU:</b>	<b>CHASSIS</b>	<b>MIRROR 1</b>	Performs and displays all self test functions sequentially in the format: STEP ## DMX:###	
			<b>MIRROR 2</b>		
<b>DISPLAY TEST</b>		<b>ON</b>	Tests the display function		
		<b>OFF</b>			
<b>CODE MENU</b>				For diagnostic use	
<b>INFORMATION MENU</b>	<b>SENSOR STATUS MENU</b>	<b>MIRROR 1 ENCODER ###</b>		Displays absolute position of Mirror 1	
		<b>MIRROR 2 ENCODER #####</b>		Displays absolute position of Mirror 2	
	<b>UNIQUE NUMBER #####</b>			Displays fixture's unique 10-character number	
	<b>DMX VALUES MENU</b>	<b>BY CHANNEL</b>	<b>1:### ### ##</b>	Displays current values for Channels 001– 512 and 6 DMX values/screen. The number at the beginning of each line indicates the first channel with a value displayed on that line.	
			<b>4:### ### ##</b>		
	<b>7: ### ### ##</b>				
	<b>10:### ### ##</b>				
	<b>FIXTURE HOURS</b>				Displays fixture operation time in hours:minutes
	<b>FIXTURE HOURS RESET:</b>		<b>NO</b>	Default "safe" setting	
			<b>YES</b>	Press Enter for 5 seconds to reset fixture hours to 0	
	<b>SOFTWARE VERSION:</b>		<b>V ##.##.###</b>	Major.Minor.Build	
<b>MODULE VERSION MENU</b>		<b>MIRROR 1 HW:# SW:#</b>	Displays the Hardware and Software versions for each logic board in the fixture. Displays NOT AVAILABLE if a board does not exist in that position.		
		<b>MIRROR 2 HW:# SW:#</b>			
		<b>RS232 INTERFACE HW:# SW:#</b>			
		<b>DISPLAY NOT AVAILABLE</b>	Fixture is communicating with the board if you are viewing the display		
<b>DISPLAY ERRORS MENU</b>	<b>XXXXXXXXXXXXXXXXXXXXXXXXXXXXXXXX</b>		Scrolls through errors displayed in 2-line, 16-character format		
<b>CHANNELS NEEDED:</b>		<b>##</b>	Displays channel range for current Mirror Head configuration		
<b>NEXT DMX CHANNEL:</b>		<b>##</b>	(Current start channel + channels needed+1)		

## DMX Address Menu

---

DMX Address is the top level menu selection used to set the fixture's DMX start channel. Use this menu option, to change the *existing* DMX start channel to another DMX start channel.

### Setting a DMX Start Channel

To set the DMX start channel on the Power Hub:

1. Press the Menu button to unlock the menu system or to move back up the system to the top level menus. **DMX ADDRESS MENU** is the first menu item at the top level.
1. Press the Enter button to select. The display will show **SET DMX START CHANNEL:###**. The display will show the start channel currently assigned to the fixture.
2. Use the up and down arrows on the Navigation button to select a new DMX start channel, if necessary. The display will flash a new option ready for selection.

**Note:** *The last valid Start channel for a fixture is based on the channel range required by fixture's module configuration. The last valid Start channel for the Orbital Head System 507 (512–6+1).*

3. Press the Enter button to accept the new DMX Start channel.

**Note:** *If the Enter button is not pressed, the old value will remain selected after exiting the menu.*

## Set Parameters Menu

---

The Set Parameters menu sets all factory options to their default settings or changes the factory options individually.

### Factory Default Settings

If any of the Orbital head default settings are changed, this menu reverts to the OFF option. The ON option restores all factory defaults.

To check and reset factory defaults:

1. Press the Menu button to unlock the menu system or to move back up the system to the top level menus.
2. Using the left and right arrows on the Navigation button, scroll through the top level to **SET PARAMETERS MENU** and press the Enter button to select.
3. Using the left and right arrows on the Navigation button, scroll to **FACTORY DEFAULT SETTINGS**. The current state (ON or OFF) will be displayed.
4. To reinstate the factory defaults if OFF is displayed, use the up and down arrows on the Navigation button to scroll to ON and press the Enter button to select.

## Display Level

Use this menu option to turn the display on or off.

To change display level:

1. Press the Menu button to unlock the menu system or to move back up the system to the top level menus.
2. Using the left and right arrows on the Navigation button, scroll through the top level to SET PARAMETERS MENU and press the Enter button to select.
3. Using the left and right arrows on the Navigation button, scroll to the DISPLAY LEVEL.
4. Using the up and down arrows on the Navigation button, choose ON to turn the display on or OFF to dim the display and press the Enter button to store the option.

## Lamp Control

Use this menu option controls striking and dousing the lamp automatically or manually from the menu system or the DMX console.

To set :

1. Press the Menu button to unlock the menu system or to move back up the system to the top level menus.
2. Using the left and right arrows on the Navigation button, scroll through the top level to SET PARAMETERS MENU and press the Enter button to select.
3. Using the left and right arrows on the Navigation button, scroll to the LAMP CONTROL and press the Enter button to select.
4. Using the up and down arrows on the Navigation button, choose AUTOMATIC to initiate a lamp strike automatically on start up and douses the lamp after a DMX data loss of 5 minutes or MANUAL to control lamp strike manually.

## Mirror 2 Quick Path

Turning this menu option ON directs the outer mirror to take the shortest path to the selected position to provide very fast position changes. The default is OFF.

To turn Mirror 2 Quick Path ON:

1. Press the Menu button to unlock the menu system or to move back up the system to the top level menus.
2. Using the left and right arrows on the Navigation button, scroll through the top level to SET PARAMETERS MENU and press the Enter button to select.
3. Using the left and right arrows on the Navigation button, scroll to the MIRROR 2 QUICK PATH.
4. Using the up and down arrows on the Navigation button, choose ON and press the Enter button to store the option.

## LensType

Use this menu option to optimize the Orbital head for the specific projector you are using.

To select the lens type:

1. Press the Menu button to unlock the menu system or to move back up the system to the top level menus.
2. Using the left and right arrows on the Navigation button, scroll through the top level to SET PARAMETERS MENU and press the Enter button to select.
3. Using the left and right arrows on the Navigation button, scroll to the LENS TYPE.
4. Using the up and down arrows on the Navigation button, navigate to the appropriate throw ratio for your projectors lens and press Enter to select.

## Fixture Mode Menu

---

The Mode menu sets the module and protocol configuration and crossloads software from one fixture to other Orbital Head System systems on the link.

### Crossloading Fixture Software

A fixture running a newer software version can load the new software to all other Orbital Head Systems on the link using the CROSSLOAD FIRMWARE menu option.

To CROSSLOAD FIRMWARE from one fixture to all Orbital Head System systems on the link:

1. Disconnect or bypass any controllers, serial data distributors, data line optoisolators, and any fixtures using RS-422 communications (such as Dataflash<sup>®</sup> AF1000 xenon strobes, and Intellabeam<sup>®</sup> fixtures). These devices will block communication between the crossloading fixture and any other Orbital Head System systems on the link.
2. On the crossloading fixture *only*, unlock the menu system by pressing and holding down the Menu button until the extended 2-line display appears indicating the top menu level.
3. Using the left and right arrows on the Navigation button, scroll to the FIXTURE MODE MENU and press the Enter button to select.
4. Use the left and right arrows on the Navigation button to scroll to CROSSLOAD FIRMWARE.
5. Use the up and down arrows on the Navigation button to scroll to the YES option and press the Enter button to store. The fixture will upload its software to all other Orbital Head System systems on the link.

When the crossload has finished successfully, CROSSLOADING COMPLETE will appear briefly in the display of the crossloading fixture, and all other fixtures will automatically home.

**Note:** *If a new boot code was included with the latest software, the fixture displays a BOOTDIFF error when it returns to the locked mode of the menu system. To correct the boot code, copy the new boot code to each fixture (see "Copying the Boot Code" on page 34-24).*

## Protocol Mode

This option sets the Protocol to be followed in assigning Start Channels and programming parameters. STANDARD protocol is the default.

## Test Options Menu

---

The TEST OPTIONS MENU manually homes the fixture, performs fixture self tests, and stores new boot code information. Performing fixture self tests may help identify mechanical problems in the fixture.

## Copying the Boot Code

When new software is uploaded to a Orbital Head System, it may contain a new boot code which must be copied to each fixture. This is apparent if the fixture displays a BOOTDIFF error.



**Caution: Do not remove power from the fixture while performing a boot copy.**

To accept and store the new boot code:

1. Press the Menu button to unlock the menu system or to move back up the system to the top level menus.
2. Using the left and right arrows on the Navigation button, scroll to the TEST OPTIONS MENU and press the Enter button to select.
3. Using the left and right arrows on the Navigation button, scroll to the COPY BOOT option and press the Enter button to select.
4. Use the up and down arrows on the Navigation button to scroll to the YES option and then press the Enter button to store the command. The fixture will store the new boot code, then automatically home.

## Homing the Fixture

The Orbital Head System automatically homes all its functions whenever it is turned on. This menu option manually homes the entire fixture.

To remotely home the fixture using a DMX controller, see *Roadster Orbital Head Positioning* on page 29 and *Control Function* on page 31.

To manually home the fixture:

1. Press the Menu button to unlock the menu system or to move back up the system to the top level menus.
2. Use the left and right arrows on the Navigation button to scroll to the TEST OPTIONS MENU and press the Enter button to select.
3. Use the left and right arrows on the Navigation button to scroll to HOME FIXTURE.
4. Press the Enter button to select all to home the orbital head.

## Self Test Menu

This option displays the steps and DMX values generated as the fixture tests the motor operation of various functions. Self test can be run and viewed on all the fixture parameters sequentially, or individual parameters.

To access the SELF TEST MENU:

1. Press the Menu button to unlock the menu system or to move back up the system to the top level menus.
2. Use the left and right arrows on the Navigation button to scroll to the TEST OPTIONS MENU and press the Enter button to select. The menu displays CHASSIS.
3. Press the Enter button to select.
4. Scroll between MIRROR 1 and MIRROR 2. Press the Enter button to select. The fixture begins running the selected self test.

## Information Menu

---

The Information menu displays current fixture information such as sensor status, total fixture hours, hardware and software versions, DMX errors, and DMX data for any device on the link. Fixture hours resets are also executed in the Information Menu.

## Channels Needed

Use this option to view the number of channels required (channel range) for the fixture's specific configuration. The Orbital Head System requires 12 channels on a DMX link.

## Display Errors

This menu option displays current errors in a descriptive 32-character text field.

To DISPLAY ERRORS:

1. Press the Menu button to unlock the menu system or to move back up the system to the top level menus.
2. Use the left and right arrows on the Navigation button to scroll to the INFORMATION MENU and press the Enter button to select.
3. Use the left and right arrows on the Navigation button to scroll to the DISPLAY ERRORS menu option and press the Enter button to select.
4. Use the up and down arrows on the Navigation button to view the list of current errors.

## DMX Values Menu

Use this menu option to view current DMX value settings by channel or by parameters. A Orbital Head System utilizes 12 channels on a DMX 512 link. Each DMX value is from 0-255.

When viewing DMX value settings by Channel, the Orbital Head System displays current values for Channels 001– 512 in two lines of three DMX values each per screen. The number at the beginning of each line indicates the first channel with a value displayed on that line.

When viewing current DMX value settings by the Parameters, the menu displays one parameter with the DMX value below it per screen. Parameters will change for different module configurations.

To access the DMX VALUES MENU:

1. Press the Menu button to unlock the menu system or to move back up the system to the top level menus.
2. Use the left and right arrows on the Navigation button to scroll to the INFORMATION MENU and press the Enter button to select.
3. Use the left and right arrows on the Navigation button to scroll to the DMX VALUES MENU and press the Enter button to select.
4. Use the up and down arrows scroll through the channel range. The display shows 6 DMX values per screen in two lines of 3 values each. The number at the beginning of the line indicates the channel number corresponding to the first value in that line.

## Fixture Hours

Use this option to view the fixture operation time in hours and minutes.

## Fixture Hours Reset

Use this option to reset the fixture operation time to Zero.

To access the FIXTURE HOURS RESET option:

1. Press the Menu button to unlock the menu system or to move back up the system to the top level menus.
2. Use the left and right arrows on the Navigation button to scroll to the INFORMATION MENU and press the Enter button to select.
3. Use the left and right arrows on the Navigation button to scroll to the FIXTURE HOURS RESET option and press the Enter button to select.
4. Use the up and down arrows on the Navigation button to scroll to YES. Press and hold the Enter button down for 5 seconds to select.

## Module Version Menu

This option display's the hardware and software version number for each logic board in the fixture as a troubleshooting method for checking communication with the different boards in the fixture. Displays NOT AVAILABLE if a board does not exist in that position.

**Note:** *Due to programming functionality, the Display option always displays NOT AVAILABLE. even though communication with the board is active whenever you can view the display.*

## Next DMX Channel

Use this option to view the next available DMX start channel on the link following this fixture and is based on the fixture's specific configuration. The value displayed uses the formula (current Start channel + channels needed for this fixture +1).

## Sensor Status Menu

The Sensor Status displays the current numeric position of the fixture's encoders.

To view encoder values:

To access the DMX VALUES MENU:

1. Press the Menu button to unlock the menu system or to move back up the system to the top level menus.
2. Use the left and right arrows on the Navigation button to scroll to the INFORMATION MENU and press the Enter button to select.
3. Use the left and right arrows on the Navigation button to scroll to the SENSOR MENU and press the Enter button to select.
4. Use the left and right arrows on the Navigation button to scroll to view MIRROR 1 ENCODER or MIRROR 2 ENCODER value.

## Software Version

This option display's the fixture's CPU board Software version. The version number is composed of: V(Major).(Minor).(Build)

## Unique Number

Each Orbital Head System has a unique number similar to a serial number. TalkBack™ protocol uses this number to identify a fixture for remote communication over a DMX link. Use this option to view the fixture's unique number.

## Power Hub Maintenance

---

### Replacing the Power Hub Fuse



**Warning: Disconnect power before servicing.**  
**This fixture must only be serviced by qualified personnel. The following information is intended to assist qualified personnel only.**  
**Replace fuses with the specified type and rating only.**

To replace a fuse:

1. Disconnect power to the power supply hub.
2. Remove the three screws on the back of the power supply hub and lift the cover.
3. Locate the fuse on the bridge over the power supply.
4. Replace the Power supply fuse with the following:

Fuse Type and Rating	Manufacturer	High End Systems p/n
2.5A, 250V, Slow Blow	Littelfuse 215 02.5	90403027

### Replacement Parts

The Orbital Head System has no user-serviceable parts. To return it for servicing, call your High End Systems dealer/distributor for a Return Material Authorization (RMA) number. High End Systems cannot accept any goods shipped without an RMA number. For more information, see "Warranty Information" on page v.

### Cleaning the Mirrors

If the mirrors become dirty, clean them using a mild glass cleaner (containing no ammonia) and a soft, lint-free cotton cloth.

# Chapter 4:

## DMX Programming

### DMX Programming Terminology

---

A Parameter (construct) is a fixture attribute that can be controlled to modify the light beam in terms of color, beam quality and pattern, intensity, or focus (position). To program fixtures, DMX values are assigned to each of the fixture's parameters according to that fixture's DMX protocol.

A cue (sometimes referred to as a *scene* or *look* depending on the controller used) is one set of attribute options. Combining cues into sequences, assigning times and synchronizing fixtures on a link are the basics of show creation. Using a DMX controller, a designer can control all the fixtures on a link programming an unlimited number of sequences and their associated timing.

### DMX Parameters

---

#### Roadster Orbital Head Positioning

The **Mirror1** and **Mirror 2** parameters each use two channels for for 16-bit control of the Orbital Head's movement direction and speed. The Orbital Head positions the projected image by independently moving the inner and outer mirrors on the Mirror Head. The inner mirror (Mirror 1) maps to Pan on DMX control consoles and can move from 0°–270°. The outer mirror (Mirror 2) maps to Tilt on DMX controllers and has a range of 0°–360°.

#### Focus

The **Focus** parameter uses two DMX channels to control the projector focus with 16-bit accuracy.

#### Zoom

The **Zoom** parameter uses two DMX channels to control the motion of the projector's zoom lens with 16-bit accuracy.

#### Shutter

The **Shutter** parameter uses one DMX channel to control the projector shutter. A DMX value < 24 closes the shutter. A DMX value > 231 opens the shutter.

## MSpeed (Motor Speed)

The **MSpeed** parameter controls the time required for a motor to complete movement when changing from one position to another from the longest (DMX value = 0) to the shortest (DMX value = 65535). MSpeed provides a means for all motors to reach their target position at the same time, even though each motor may have different distances to travel. MSpeed movement is extremely smooth because the fixture controls movements independent of DMX refresh rates. MSpeed provides a balance between quick response and smooth motion with some lag.

MSpeed times vary from 0.15 seconds to 252.7 seconds. However, when MSpeed is applied to a parameter, the delay value (length of time allowed for the entire scene) needs to be longer than the MSpeed value to allow the motors to complete their movement before the end of the cue.

An MSpeed value that is longer than the delay value can be used to smoothly change directions or in creating circles or ballyhoos. It could also produce an undesirable result; for example, no light output during the scene. For a listing of exact MSpeed times, see *MSpeed Conversion Table* on page 33.

**Note:** *The MSpeed option applies to Mirror Head movement speed. Mirror head speed can also be varied using XFADE time on most DMX consoles. If a DMX controller cannot perform a smooth 16-bit XFADE, an MSpeed between 95-99% may greatly improve smoothness.*

## Control Function

The Control parameter provides access to a number of Power Hub and Projector commands from the control desk.

Parameter DMX Value		Control Option	Description
Shutter	Control		
0-255	0-9	Safe	Disables all Control settings for normal operation.
	10-19	Pan & Tilt MSpeed Off	Sets Pan & Tilt MSpeed off.
0	20-28	Display Off	Sets display to off.
	30-38	Display Dim	Dims display characters.
	40-48	Display Bright	Brightens the display characters.
	60-68	Home All	Remotely homes the Orbital Head pan and tilt functions.
	70-78	Home ILS	Remotely detects the projector's intelligent lens system after a lens change and homes the focus and zoom .
	80-88	Lamp On	Remotely restrikes the fixture's lamp.
	90-98	Lamp Off	Remotely extinguishes the fixture's lamp.
	100-105	ILS On	Remotely turns on the projector's intelligent lens system on and allows focus and zoom control via RS-232. ILS off is the projector's initial default. Use this option when the ILS gets inadvertently turned off, or if the projector is replaced.
	120-130	Shutdown	Shuts down the fixture. The lamp is off, power to the motors is disabled, and the display reads [SHUTDOWN]. Homing the fixture brings it back into operation.
0-255	141-150	Horizontal offset right	These options are live so that the shutter can be open and you can center the image on the mirror. The commands work like a remote control. Issue a left command and the lens moves left until a stop is issued, or the lens reaches the end of travel. Likewise with up, down and right. These commands are best written as presets that can issued once rather than live dimming or scrolling from command to command.
	151-160	Horizontal offset stop	
	161-170	Horizontal offset left	
	171-180	Vertical offset up	
	181-190	Vertical offset stop	
	191-200	Vertical offset down	

## DMX Protocol Table

The Roadster Orbital Head System is patched by a DMX controller as an individual fixture on a DMX link and requires a 12-channel range.

Chan #	Function	Description	Value dec.	Default	Value %	Default	
1	Mirror 1 Coarse	Moves inner mirror from 0°–270° (Maps to Pan)	0-	32768	0-100	50	
2	Mirror 1 Fine		65535				
3	Mirror 2 Coarse	Moves outer mirror from 0°–360° (Maps to Tilt)	0-	32768	0-100	50	
4	Mirror 2 Fine		65535				
5	Focus Coarse	16-bit adjustment of	0-	32768	0-100	50	
6	Focus Fine		65535				
7	Zoom Coarse	16-bit adjustment	0-	32768	0-100	50	
8	Zoom Fine		65535				
9	Shutter	Closed	0-23		0-9		
		Open	232-255		91-100		
10	MSpeed (See Appendix B for conversion tables)	Disable	0	0	0	0	
		Set from Longest (253.7 sec to Shortest (0.15 sec)	4-255		1-100		
11	Control Function	<b>The Control channel should not be crossfaded. No shutter channel requirement.</b>					
		Safe (normal operation )	0-9	0	0-4	0	
		Pan & Tilt Mspeed Off	10-19		4-7		
		<b>Set Shutter to 0 to access the following commands</b>					
		Display Off (send 20 packets)	20-28	0	8-11	0	
		Display Dim (send 20 packets)	30-38		12-15		
		Display Bright (send 20 packets)	40-48		16-19		
		Home (send 20 packets)	60-68		24-27		
		Home Lens (send 20 packets)	70-78		27-31		
		Lamp On (send 20 packets)	80-88		31-35		
		Lamp Off (send 20 packets)	90-98		35-38		
		LDM on (send 20 packets)	100-105		39-41		
		Shutdown (send 80 packets)	120-130		47-51		
		Reserved for future use	131-140		51-55		
		<b>Live Commands - Shutter does not need to be set to 0</b>					
		Lens horizontal offset right	141-150	0	55-59	0	
		Lens horizontal offset stop	151-160		59-63		
Lens horizontal offset left	161-170	63-67					
Lens vertical offset up	171-180	67-71					
Lens vertical offset stop	181-190	71-75					
Lens vertical offset down	191-200	75-78					
Reserved for future use	201-255	79-100					
12	Control	Reserved for future use	0-255		0-100		

# Appendix A: MSpeed Conversion Table

The following table lists the MSpeed (motor) movement times and their corresponding DMX controller values. If you have a numeric-type controller, use the Value Decimal (dec.) column. If you have a fader-type controller, use the Value Percentage (%) column. If your controller allows you to program hex values, use the Value (hex) column.

Time (sec.)	Value (dec.)	Value (%)	Value (hex)	Time (sec.)	Value (dec.)	Value (%)	Value (hex)	Time (sec.)	Value (dec.)	Value (%)	Value (hex)
0.15	255	100	FF	6.25	216	85	D8	24.54	177	69	B1
0.15	254	100	FE	6.56	215	84	D7	25.17	176	69	B0
0.17	253	99	FD	6.89	214	84	D6	25.80	175	69	AF
0.19	252	99	FC	7.22	213	84	D5	26.45	174	68	AE
0.21	251	98	FB	7.56	212	83	D4	27.10	173	68	AD
0.25	250	98	FA	7.91	211	83	D3	27.76	172	67	AC
0.29	249	98	F9	8.27	210	82	D2	28.43	171	67	AB
0.35	248	97	F8	8.63	209	82	D1	29.11	170	67	AA
0.41	247	97	F7	9.00	208	82	D0	29.80	169	66	A9
0.47	246	96	F6	9.39	207	81	CF	30.49	168	66	A8
0.55	245	96	F5	9.77	206	81	CE	31.19	167	65	A7
0.63	244	96	F4	10.17	205	80	CD	31.90	166	65	A6
0.73	243	95	F3	10.58	204	80	CC	32.62	165	65	A5
0.83	242	95	F2	10.99	203	80	CB	33.34	164	64	A4
0.94	241	95	F1	11.41	202	79	CA	34.08	163	64	A3
1.05	240	94	F0	11.84	201	79	C9	34.82	162	64	A2
1.18	239	94	EF	12.28	200	78	C8	35.57	161	63	A1
1.31	238	93	EE	12.72	199	78	C7	36.33	160	63	A0
1.45	237	93	ED	13.17	198	78	C6	37.09	159	62	9F
1.60	236	93	EC	13.63	197	77	C5	37.87	158	62	9E
1.75	235	92	EB	14.10	196	77	C4	38.65	157	62	9D
1.92	234	92	EA	14.58	195	76	C3	39.44	156	61	9C
2.09	233	91	E9	15.07	194	76	C2	39.44v	156	61	9C
2.27	232	91	E8	15.56	193	76	C1	40.23	155	61	9B
2.46	231	91	E7	16.06	192	75	C0	41.04	154	60	9A
2.66	230	90	E6	16.57	191	75	BF	41.85	153	60	99
2.86	229	90	E5	17.09	190	75	BE	42.68	152	60	98
3.07	228	89	E4h	17.61	189	74	BD	43.50	151	59	97
3.29	227	89	E3	18.14	188	74	BC	44.34	150	59	96
3.52	226	89	E2	18.68	187	73	BB	45.19	149	58	95
3.76	225	88	E1	19.23	186	73	BA	46.04	148	58	94
4.00	224	88	E0	19.79	185	73	B9	46.90	147	58	93
4.25	223	87	DF	20.36	184	72	B8	47.77	146	57	92
4.52	222	87	DE	20.93	183	72	B7	48.65	145	57	91
4.78	221	87	DD	21.51	182	71	B6	49.54	144	56	90
5.06	220	86	DC	22.10	181	71	B5	50.43	143	56	8F
5.34	219	86	DB	22.70	180	71	B4	51.33	142	56	8E
5.64	218	85	DA	23.30	179	70	B3	52.24	141	55	8D
5.94	217	85	D9	23.92	178	70	B2	53.16	140	55	8C

Time (sec.)	Value (dec.)	Value (%)	Value (hex)	Time (sec.)	Value (dec.)	Value (%)	Value (hex)	Time (sec.)	Value (dec.)	Value (%)	Value (hex)
54.09	139	55	8h	109.28	90	35	5A	187.17	39	15	27
55.02	138	54	8A	110.61	89	35	59	188.90	38	15	26
55.96v	137	54	89	111.94	88	35	58	190.65	37	15	25
56.91	136	53	88	113.28	87	34	57	192.40	36	14	24
57.87	135	53	87	114.63	86	34	56	194.16	35	14	23
58.84	134	53	86	115.99	85	33	55	195.92	34	13	22
59.81	133	52	85	117.36	84	33	54	197.70	33	13	21
60.79	132	52	84	118.73	83	33	53	199.48	32	13	20
61.78	131	51	83	120.12	82	32	52	201.28	31	12	1F
62.78	130	51	82	121.5v	81	32	51	203.08	30	12	1E
63.79	129	51	81	122.91	80	31	50	204.88	29	11	1D
64.80	128	50	80	124.31	79	31	4F	206.70	28	11	1C
65.82	127	50	7F	125.73	78	31	4E	208.52	27	11	1B
66.85	126	49	7E	127.15	77	30	4D	210.36	26	10	1A
67.89	125	49	7D	128.58	76	30	4C	212.19	25	10	19
68.94	124	49	7C	130.02	75	29	4B	214.04	24	9	18
69.99	123	48	7B	134.39	72	28	48	215.90	23	9	17
71.05	122	48	7A	135.86	71	28	47	217.76	22	9	16
72.13	121	47	79	137.34	70	27	46	219.63	21	8	15
73.20	120	47	78	138.82	69	27	45	221.51	20	8	14
74.29	119	47	77	140.32	68	27	44	223.40	19	7	13
75.38	118	46	76	141.82	67	26	43	225.30	18	7	12
76.49	117	46	75	143.33	66	26	42	227.20	17	7	11
77.60	116	45	74	144.85	65	25	41	229.11	16	6	10
78.71	115	45	73	146.38	64	25	40	231.03	15	6	0F
79.84	114	45	72	147.92	63	25	3F	232.96	14	5	0E
80.98	113	44	71	149.46	62	24	3E	234.90	13	5	0D
82.12	112	44	70	151.01	61	24	3D	236.84	12	5	0C
83.27	111	44	6F	152.57	60	24	3C	238.79	11	4	0B
84.43	110	43	6E	154.14	59	23	3B	240.75	10	4	0A
85.59	109	43	6D	155.71	58	23	3A	242.72	9	4	09
86.77	108	42	6C	157.30	57	22	39	244.70	8	3	08
87.95	107	42	6B	158.89	56	22	38	246.68	7	3	07
89.14	106	42	6A	160.49	55	22	37	248.68	6	2	06
90.34	105	41	69	162.09	54	21	36	250.68	5	2	05
91.55	104	41	68	163.71	53	21	35	246.68	7	3	07
92.76	103	40	67	165.33	52	20	34	248.68	6	2	06
93.98	102	40	66	166.96	51	20	33	250.68	5	2	05
95.21	101	40	65	168.60	50	20	32	252.68	4	2	04
96.45	100	39	64	170.25	49	19	31				
97.70	99	39	63	171.91	48	19	30				
98.95	98	38	62	173.57	47	18	2F				
100.22	97	38	61	175.24	46	18	2E				
101.49	96	38	60	176.92	45	18	2D				
102.77	95	37	5F	178.61	44	17	2C				
104.05	94	37	5E	180.30	43	17	2B				
105.35	93	36	5D	182.01	42	16	2A				
106.65	92	36	5C	183.72	41	16	29				
107.96	91	36	5B	185.44	40	16	28				

# Appendix B:

## Safety Information

### **Warning: For Continued Protection Against Fire**

1. This equipment for connection to branch circuit having a maximum overload protection of 20 A.

### **Warning: For Continued Protection Against Electric Shock**

1. If this equipment was received without a line cord plug, attach the appropriate line cord plug according to the following code:
  - brown–line
  - blue–neutral
  - green/yellow–earth
2. As the colours of the cores in the mains lead of this equipment may not correspond with the coloured markings identifying the terminals in your plug, proceed as follows:
  - the core which is coloured green and yellow must be connected to the terminal in the plug which is marked with the letter E or by the earth symbol , or coloured green or green and yellow.
  - the core which is coloured blue must be connected to the terminal which is marked with the letter N or coloured black.
  - the core which is coloured brown must be connected to the terminal which is marked with the letter L or coloured red.
3. Class I equipment. This equipment must be earthed.
4. Equipment suitable for dry locations only. Do not expose this equipment to rain or moisture.
5. Refer servicing to qualified personnel; no user serviceable parts inside.

## Appendice B: Importantes Informations Sur La Sécurité

### Mise En Garde: Pour Une Protection Permanente Contre Les Incendies

1. Cet appareil de connection au circuit comporte une protection contre les surcharges de 20 A.

### Mise En Garde: Pour Une Protection Permanente Contre Les Chocs Électriques

1. Si cet équipement est livré sans prise de cable, veuillez connecter la prise de cable correcte selon le code suivant:
  - marron - phase
  - bleu - neutre
  - vert/jaune - terre
2. Débrancher le courant avant de changer les lampes ou d'effectuer des réparations.
3. Cet équipement doit être uniquement utilisé dans des endroits secs. Ne pas l'exposer à la pluie ou l'humidité.
4. À l'intérieur de l'équipement il n'y a pas de pièces remplaçables par l'utilisateur. Confiez l'entretien à un personnel qualifié.
5. Equipement de Classe I. Cet équipement doit être mis à la terre.

## Anhang B: Wichtige Hinweise Für Ihre Sicherheit

### **Warnung: Zum Schutz Vor Brandgefahr**

1. Dieses Gerät darf nur an eine Zweigleitung mit einem Überlastungsschutz von höchstens 20 A angeschlossen werden.

### **Warnung: Zum Schutz Gegen Gefährliche Körperströme**

1. Wenn dieses Gerät ohne einen Netzkabelstecker erhalten wurde, ist der entsprechende Netzkabelstecker entsprechend dem folgenden Code anzubringen:
  - Braun - Unter Spannung stehend
  - Blau - Neutral
  - Grün/Gelb - Erde
2. Vor dem Austauschen von Lampen oder vor Wartungsarbeiten stets den Netzstecker ziehen.
3. Diese Geräte sind nur zum Einbau in trockenen Lagen bestimmt und müssen vor Regen und Feuchtigkeit geschützt werden.
4. Servicearbeiten sollten nur von Fachpersonal ausgeführt werden. Das Gerät enthält keine wartungsbedürftigen Teile.
5. Dieses Gerät gehört zur Klasse I. Dieses Gerät muß geerdet werden.

## Apéndice B: Información Importante De Seguridad

### **Advertencia: Para Protección Continua Contra Incendios**

1. Este equipo debe conectarse a un circuito que tenga una protección máxima contra una sobrecargas de 20 A.

### **Advertencia: Para La Protección Continua Contra Electrocuiones**

1. Si se recibió este equipo sin el conector de alimentación, monte usted el conector correcto según la clave siguiente:
  - moreno - vivo
  - azul - neutral
  - verde/amarillo - tierra
2. Desconecte el suministro de energía antes de cambiar lámparas o prestar servicio de reparación.
3. Este equipo está diseñado para usarse en lugares secos no lo exponga a la lluvia o humedad.
4. Derive el servicio de reparación de este equipo al personal calificado. El interior no contiene repuestos que puedan ser reparados por el usuario.
5. Equipo de Clase I. Este equipo debe conectarse a tierra.

## Appendice B: Importanti Informazioni Di Sicurezza

### **Avvertenza: Per Prevenire Incendi**

1. Questa apparecchiatura e' da collegarsi ad un circuito con una protezione da sovraccarico massima di 20 ampere.

### **Avvertenza: Per Prevenire Le Scosse Elettriche**

1. Da non montare sopra una superficie infiammabile.
2. Mantenere l' apparecchio a un minimo di 1.0 metri (3.28 piedi) di distanza dai materiali combustibili.
3. Sostituire i fusibili usando soltanto quelli del tipo e della taratura adatta.
4. Mantenere una distanza minima di 1.0 metri (3.28 piedi) dagli oggetti accesi.
5. Questa apparecchiatura e' da collegarsi ad un circuito con una protezione da sovraccarico massima di 20 ampere.

## Vigtig Sikkerhedsinformation

Advarsel: Beskyttelse mod elektrisk chock.

VIGTIGT! LEDEREN MED GUL/GROEN ISOLATION MAA KUN TILSLUTTETTES KLEMME MAERKET

 ELLER .

