

DBA007

REV.	DESCRIPTION	DATE	ENG	ECO #	APPR
1	EXPLODE VIEW, ADD BOM TABLE	07JUL04	LR		
2	ADD STRAIN RELIEF	03AUG04	LR		
3	ADD FULL TURN SCREWS, POWER CORD, ETHERNET CONN	13SEP04	LR		
4	ADDED CABLE CLAMPS ITEMS #7 & 8	23NOV04	DF		
5	ADDED 2ND USB CABLE AND HARDWARE	16MAY05	DF		
6	ADDED S-VIDEO CABLE RETAINER AND HARDWARE	27MAY05	DF		

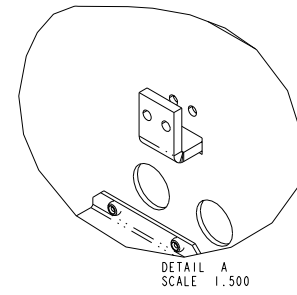
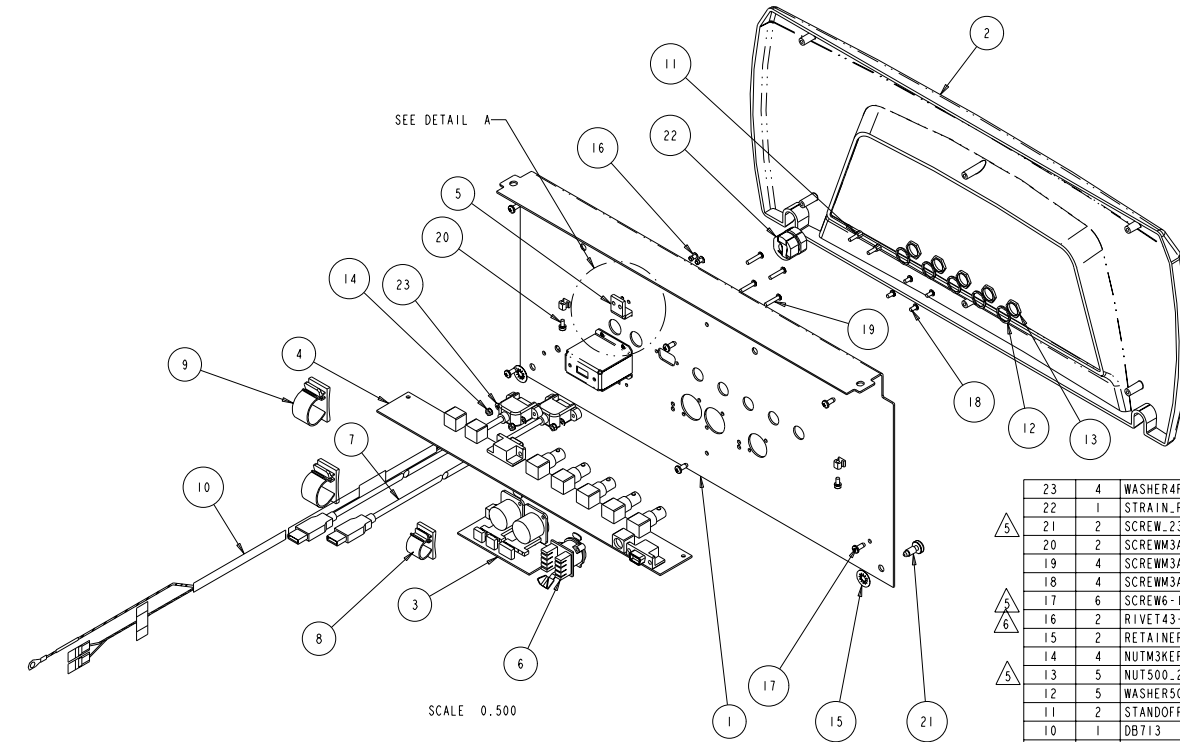

ITEM NO.	QTY.	FILENAME	PART NO.	REV	DESCRIPTION
23	4	WASHER4FLAT	90706008		WASHER, #4 M/S FLATWASHER S2
22	1	STRAIN_RELIEF_HEYCO1244	90410073		STRAIN RELIEF, HEYCO #1244
21	2	SCREW_230_611LG_CAPTIVE	90712007		SCREW,CAPTIVE PHIL .23 OD X .611 LG CR
20	2	SCREW3AC06BZ	91000306		SCREW, M3 SOCKET CAP 06 BZ SEMS
19	4	SCREW3AB16BZ	91010316		SCREW, M3 BUTTON 06 BZ NYTEMP
18	4	SCREW3AB06BZ	91010306		SCREW, M3 BUTTON 06 BZ NYTEMP
17	6	SCREW6-19PPB0380BZ	90709117		SCREW, 6-19 PHIL PAN PLASTITE 3/8 BZ
16	2	RIVET43-45DMG	90701302		RIVET, 1/8 DOMED, .157-.312
15	2	RETAINER_CAPTIVE_SS	90701362		RETAINER,CAPTIVE,SS,MED
14	4	NUTM3KEP	91201203		NUT, M3 KEPS
13	5	NUT500_28UNEF	90703092		NUT, 1/2-28UNEF-2B BNC
12	5	WASHER500_ID_LOCK_INT	90706192		LOCKWASHER, BNC INTERNAL TOOTH
11	2	STANDOFF440X347HEX_MF	90707122		JACK SCREW 440 X .347
10	1	DB713	90409202		CORD, POWER AC DL2
9	2	CLIP_75_PUSH_ON_NY	90701358		CLIP, WIRE .75 DIA, PUSH MOUNT
8	1	CLIP_50_PUSH_ON_NY	90701271		CLIP, WIRE .50 DIA, PUSH MOUNT
7	2	USB_PLUG	90409200		CABLE, USB A PANEL MOUNT 4.5" DL2
6	1	DB715	90409204		CABLE, ASSY RJ-45, DL2
5	1	DB196	99260476		BRACKET,CABLE RETAINER DL2
4	1	DB430	80030056		BOARD, I/O VIDEO SWITCH ASSY
3	1	DB438	80030066		BOARD, COMMUNICATIONS, DL2 ASSY
2	1	DB200	99350079		BEZEL, TOP BOX, DL2
1	1	DBA033	80071866	A	ASM, I/O PANEL DL2

BILL OF MATERIALS

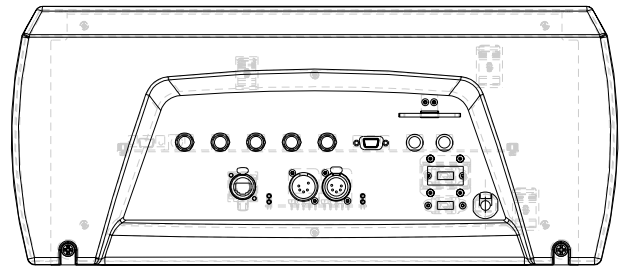

PROPRIETARY NOTICE:
 THIS DOCUMENT CONTAINS CONFIDENTIAL AND PROPRIETARY INFORMATION OF HIGH END SYSTEMS INC., (ALSO DBA LIGHTWAVE RESEARCH) AND IS GIVEN TO THE RECEIVER IN CONFIDENCE. THE RECEIVER ACCEPTS AND AGREES THAT, EXCEPT AS AUTHORIZED BY HIGH END SYSTEMS, THE RECEIVER WILL NOT PERMIT THE USE OF THE DOCUMENT OR ANY COPY THEREOF OR THE INFORMATION THEREIN, WILL NOT COPY OR PERMIT COPYING THE DOCUMENT WILL NOT DISCLOSE TO OTHERS EITHER THE DOCUMENT OR THE INFORMATION THEREIN, AND WILL UPON COMPLETION OF THE NEED TO RETAIN THE DOCUMENT, OR UPON DEMAND, RETURN THE DOCUMENT WITHOUT RETAINING ANY OF THE INFORMATION CONTAINED THEREIN IN ANY FORM WHATSOEVER.

UNLESS OTHERWISE SPECIFIED:	RELEASE DATE:	CE:	High End	2105 GRACY FARMS LANE AUSTIN, TEXAS 78758	
DIMENSIONAL TOLERANCES:	ENG:	OA:	(512) 836-2242	(512) 832-4128	
0 PLACE DECIMAL = ±0.38	MEG:	DRW: K. BICKERS	*****	http://www.highend.com	
1 PLACE DECIMAL = ±0.25	MEG:				
2 PLACE DECIMALS = ±0.13	MEG:				
ANGLES = ±0.5°	DESCRIPTION:				
	PANEL ASM, COMPLETE, I/O, DL2				
FOR PAINTED PARTS REFER TO	MATERIAL:	FINISH:			
ENG. SPEC. MANUAL WI-0592	CHARTED	N/A			
MIN. DRAFT	INTERPRET DIMENSIONS PER	PART NO.	DRAWING NO.	REV.	
MIN. RADII	ASME Y14.5M-1994	INTERNAL	DBA007	NA	
FLATNESS	THIRD ANGLE PROJECTION	DO NOT SCALE	SCALE: 0.500	SHEET: 1 OF 1	
THICKNESS	DIMENSIONS ARE IN MILLIMETERS				
VOLUME					