

TWA081

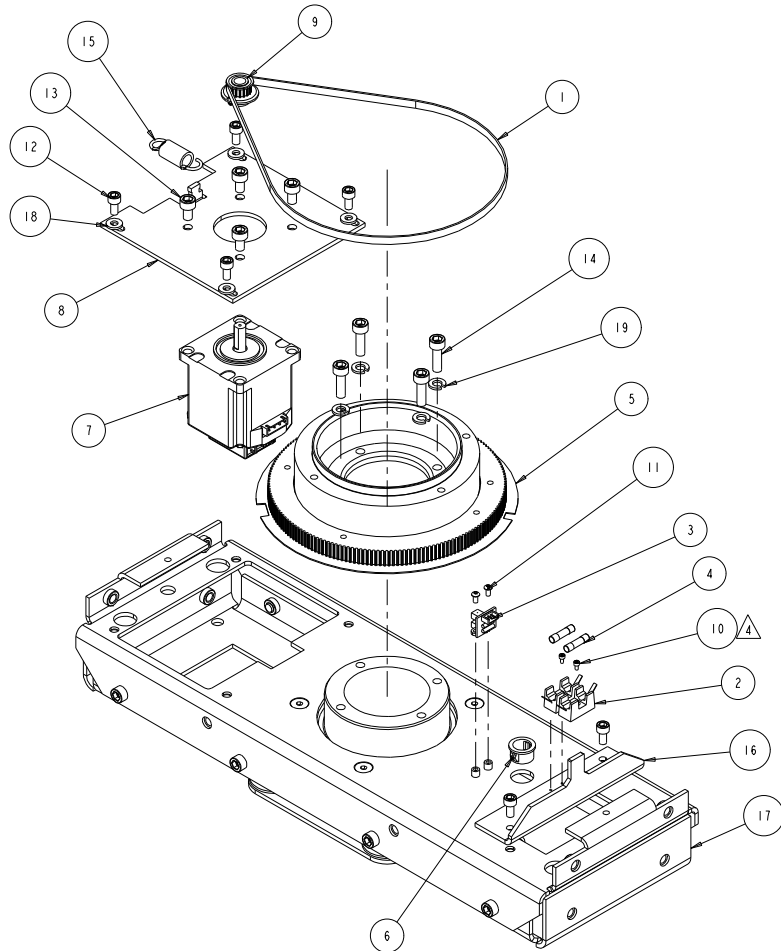

REV.	DESCRIPTION	DATE	ENG	ECO #	APPR
1	CREATE DRAWING		KDB		
2	REPLACE DB335 PINION WITH TW335 PINION	29APR08	PP		MB
3	CORRUPT FILE CAUSED INTRALINK ISSUES;;REBUILD ASSY	02OCT08	LR		
4	FUSE HOLDER: SWAP FLAT HD FOR M2 SOCKET CAP	14OCT08	LR		

ITEM NO.	QTY.	FILENAME	PART NO.	REV	DESCRIPTION
19	4	WASHER_M6_SPLITLOCK_SS	91109206	1	WASHER, LOCK, SPLIT, M6, SS
18	4	WASHER10-204X440SS	90706012	.	WASHER, FLAT #10 SS
17	1	TWA094	80460012	C	SUPPORT, ASSY, PAN BEARING V4
16	1	TW536	99260515	-	STOP, PAN LOCK, SG
15	1	SPRING500_1250_LG	90701354	-	SPRING, EXTENSION, .500 X 1.25 LG
14	4	SCREWM6AC20SS	91100620	.	SCREW, M6 SOCKET CAP 20 SS
13	4	SCREWM6AC10SS	91100610	.	SCREW, M6 SOCKET CAP 10 SS W/PATCH
12	6	SCREWM5AC10SSP	91100510	.	SCREW, M5 SOCKET CAP 10 SS W/PATCH
11	2	SCREWM3AB06BZP	91010306	.	SCREW, M3 BUTTON SOCKET HD 06 BZ W/PATCH
10	2	SCREWM2AC04BZ	91050204	.	SCREW, M2 SOCKET CAP 04 BZ
9	1	TW335	99430126	-	PINION ASSY 17T 3MM HTD, LOW PROFILE
8	1	TW527	99260505	A	MOUNT, PAN MOTOR SG
7	1	TW502	INTERNAL	3	MOTOR, ENCODER ASSEMBLY SB/SG
6	1	BUSHING500SNAP	90410102	.	GROMMET, SNAP BUSHING .50 ID
5	1	DBA015	INTERNAL	NA	GEAR ASSY, PAN DL2
4	2	FUSE5X20_5A-SLOW	90403012	.	FUSE, 5 AMP SLOW
3	1	FS709	80040022EF	1.0	BOARD, ASSY X-SPOT FLAG SENSOR
2	2	FUSE_HOLDER5X20	90412018EF	.	BLOCK, FUSE SINGLE 5 X 20MM SINGLE
1	1	TW504	99360050	.	BELT, TIMING 3MM HTD, 200 GROOVE, 6MM

UNLESS OTHERWISE SPECIFIED:		RELEASE DATE:	CE:	2105 GRACY FARMS LANE AUSTIN, TEXAS 78758 (512) 836-2242 FAX (512) 832-4128 ***** http://www.highend.com	
DIMENSIONAL TOLERANCES:		ENG:	OA:		
0 PLACE DECIMAL = ±0.38		ME:	DRW:		
1 PLACE DECIMAL = ±0.25		MEG:			
2 PLACE DECIMALS = ±0.13		DESCRIPTION:		FINISH:	
ANGLES = ±0.5°		PAN BEARING COMPLETE SG		NONE	
FOR PAINTED PARTS REFER TO ENG. SPEC. MANUAL WI-0592		MATERIAL:		PART NO.	
ALL COMPONENTS, MATERIALS AND FINISHES TO BE R6HS COMPLIANT		CHARTED		DRAWING NO.	
MIN. DRAFT		INTERPRET DIMENSIONS PER ASME Y14.5M-1994		INTERNAL TWA081	
MIN. RADIUS		THIRD ANGLE PROJECTION		REV. 4	
FLATNESS		DIMENSIONS ARE IN MILLIMETERS		DO NOT SCALE	
THICKNESS		SCALE: 0.630		SHEET: 1 OF 1	
VOLUME					

PROPRIETARY NOTICE: THIS DOCUMENT CONTAINS CONFIDENTIAL AND PROPRIETARY INFORMATION OF HIGH END SYSTEMS INC., (ALSO DBA LIGHTWAVE RESEARCH) AND IS GIVEN TO THE RECEIVER IN CONFIDENCE. THE RECEIVER ACCEPTS AND AGREES THAT, EXCEPT AS AUTHORIZED BY HIGH END SYSTEMS, THE RECEIVER WILL NOT PERMIT THE USE OF THE DOCUMENT OR ANY COPY THEREOF OR THE INFORMATION THEREIN, WILL NOT COPY OR PERMIT COPYING THE DOCUMENT OR THE INFORMATION THEREIN, AND WILL UPON COMPLETION OF THE NEED TO RETURN THE DOCUMENT, OR UPON DEMAND, RETURN THE DOCUMENT WITHOUT RETAINING ANY OF THE INFORMATION CONTAINED THEREIN IN ANY FORM WHATSOEVER.