

REV.	DESCRIPTION	DATE	ENG	ECD #	APPR
1	CREATE DRAWING	31OCT05			

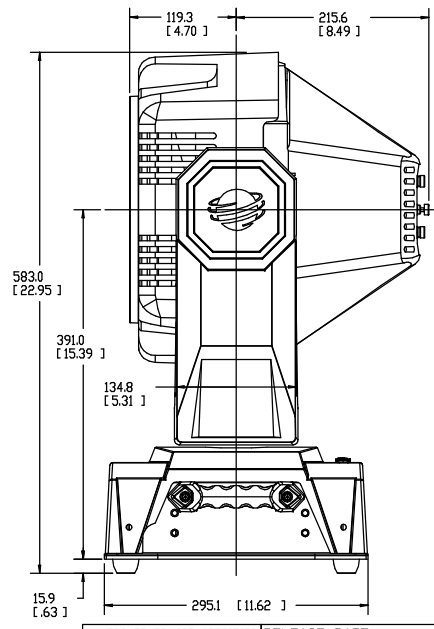
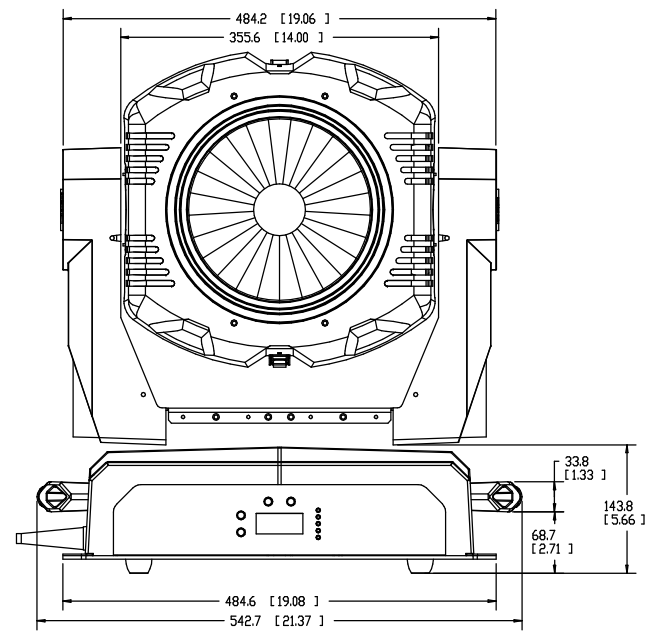
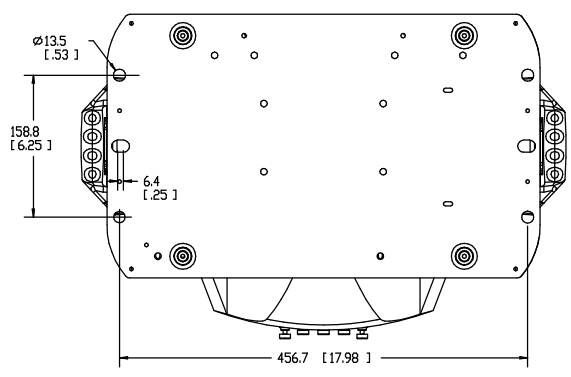
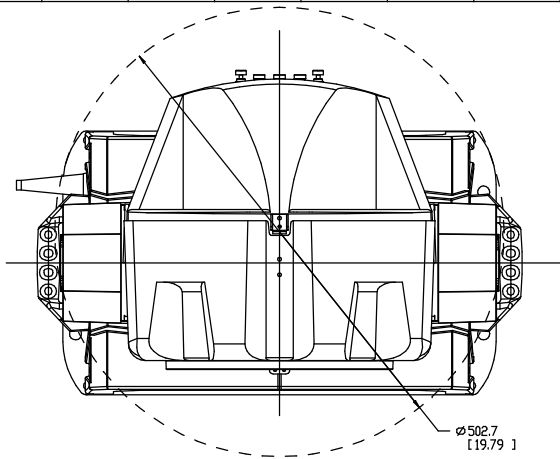

ANCILLARY DRAWING

UNLESS OTHERWISE SPECIFIED	RELEASE DATE:	CE:	High End 2105 GRACY FARMS LANE AUSTIN, TEXAS 78758 (512) 836-2242 FAX (512) 836-4128 ***** http://www.highend.com	LIGHTWAVE RESEARCH	
DIMENSIONAL TOLERANCES:	ENG:	QA:			
0 PLACE DECIMAL = ±0.38	ME:	DRW: LARRY R			
1 PLACE DECIMAL = ±0.25	MFG:				
2 PLACE DECIMALS = ±0.13	DESCRIPTION:				
ANGLES = ±0.5°	ASSY, TOP LEVEL FIXTURE S-CMD ROTATED				
FOR PAINTED PARTS REFER TO	MATERIAL:		FINISH:		
ENG. SPEC. MANUAL VI-0592	CHARTED		NA		
MIN. DRAFT					
MIN. RADII	INTERPRET DIMENSIONS PER	METRIC	PART NO.	DRAWING NO.	REV
FLATNESS	ASME Y14.5M-1994		NA	KSA001_2D_R	1
THICKNESS	THIRD ANGLE PROJECTION				
VOLUME	DIMENSIONS ARE IN MILLIMETERS		DO NOT SCALE	SCALE: 1.000	SHEET: 1 OF 1

PROPRIETARY NOTICE:
 THIS DOCUMENT CONTAINS CONFIDENTIAL AND PROPRIETARY INFORMATION OF HIGH END SYSTEMS INC. (ALSO DBA LIGHTWAVE RESEARCH) AND IS GIVEN TO THE RECEIVER IN CONFIDENCE. THE RECEIVER ACCEPTS AND AGREES THAT, EXCEPT AS AUTHORIZED BY HIGH END SYSTEMS, THE RECEIVER WILL NOT PERMIT THE USE OF THE DOCUMENT OR ANY COPY THEREOF OR THE INFORMATION THEREIN WILL NOT COPY OR PERMIT COPYING THE DOCUMENT WILL NOT DISCLOSE TO OTHERS EITHER THE DOCUMENT OR THE INFORMATION THEREIN, AND WILL, UPON COMPLETION OF THE NEED TO RETAIN THE DOCUMENT, OR UPON DEMAND, RETURN THE DOCUMENT WITHOUT RETAINING ANY OF THE INFORMATION CONTAINED THEREIN IN ANY FORM WHATSOEVER.